

Introduction to energy poverty

October 2018

KEARNEY | Energy Transition Institute

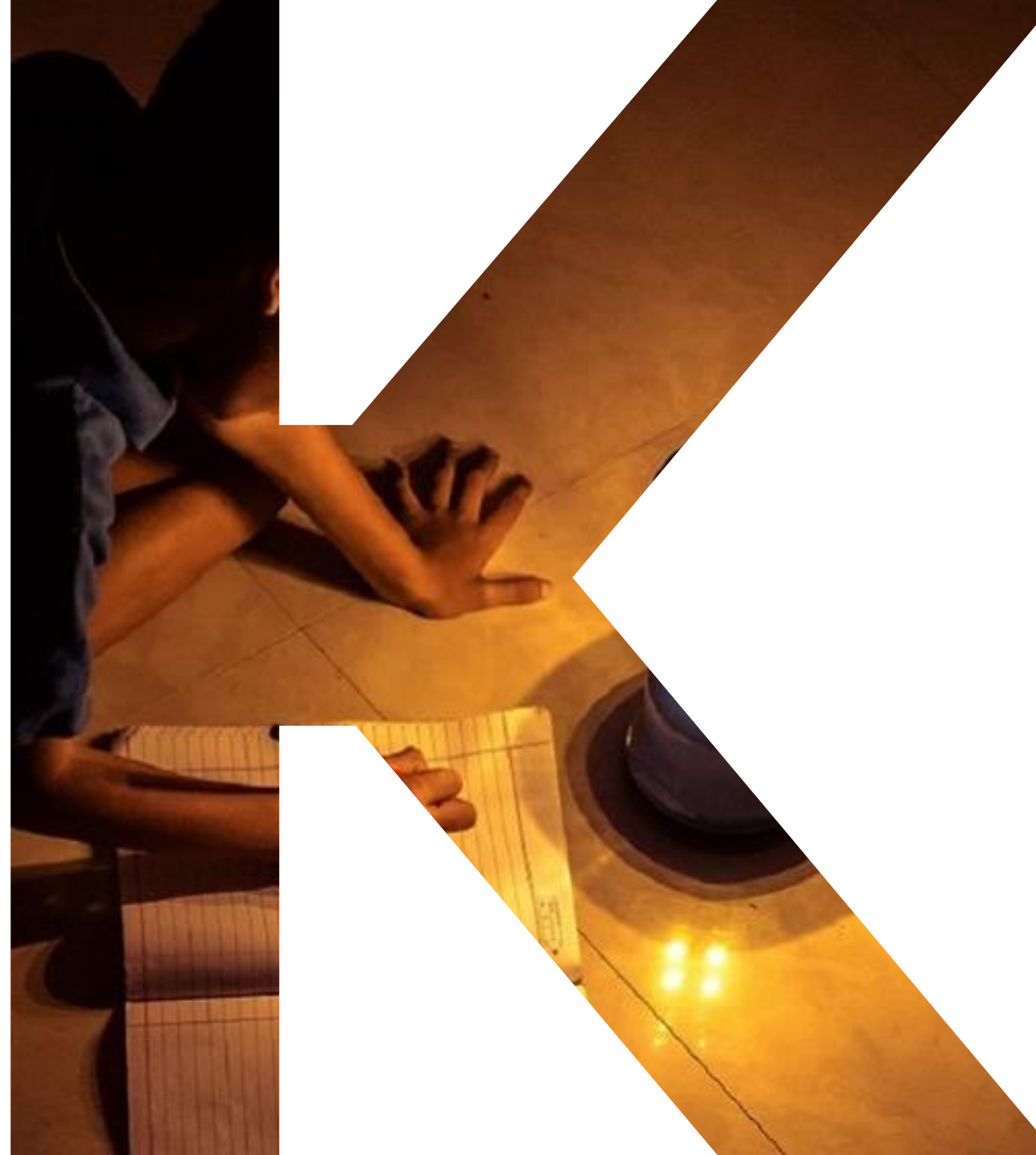

Compiled by the A.T. Kearney Energy Transition Institute

Acknowledgements

The A.T. Kearney Energy Transition Institute wishes to thank the following people for their detailed review of this FactBook: Dr. Anupama Sen, Dr. Rahmatallah Poudineh, and Dr. Bassam Fattouh from the Oxford Institute for Energy Studies; Dr. Fuad M. F. Siala from the OPEC Fund for International Development; and Dr. Adnan Shihab Eldin, Claude Mandil, and Antoine Rostand, members of the board for the Energy Transition institute. Their review does not imply that they endorse this FactBook or agree with any specific statements herein.

About the FactBook: Energy Poverty

This FactBook summarizes the status of energy poverty, first considering various definitions of the term and the methods used across the world to assess it. It evaluates the threat that energy poverty presents to society and considers projections of how the problem may evolve in the next two decades. The FactBook assesses technologies that could help provide universal access to clean, sustainable, and affordable energy and the readiness of strategies to be deployed. It also provides insights into regulation and policies designed to support solutions that could reduce or eliminate energy poverty.

About the A.T. Kearney Energy Transition Institute

The A.T. Kearney Energy Transition Institute is a nonprofit organization that provides leading insights on global trends in energy transition, technologies, and strategic implications for private-sector businesses and public-sector institutions. The Institute is dedicated to combining objective technological insights with economic perspectives to define the consequences and opportunities for decision makers in a rapidly changing energy landscape. The Institute's independence fosters unbiased primary insights and the ability to co-create new ideas with sponsors and relevant stakeholders.

Authors

The A.T. Kearney Energy Transition Institute thanks the authors of this FactBook for their contribution: Romain Debarre, Prashant Gahlot, Alija Bajramovic and Bruno Lajoie.

Energy Poverty means a lack of basic needs, profound inequality and economic stagnation; reducing it is a priority for the United Nations

In 2016, 1.1 billion people (14 percent of the global population) were without electricity and 2.8 billion (37 percent) lacked access to clean fuels. Providing clean, sustainable and affordable energy to all is a priority for governments around the world and is one of the United Nations' Sustainable Development Goals for 2030.

Human development and energy use are intrinsically linked: **energy is needed to provide for human needs, like clean air, health, food and water, education and basic human rights; and it is fundamental to the development of every economic sector.**

Household air pollution caused 3.8 million premature deaths in 2012, according to the World Health Organization. China and India are particularly badly affected, accounting for 40 percent of premature deaths in 2015; and women and children are at greater risk than men. Using clean fuels for cooking and heating could reduce these numbers. The International Energy Agency (IEA) believes that switching from traditional wood-stoves to non-solid fuel stoves would save 1.8 million lives per year.

Extending access to electricity would also significantly improve the availability of drinking water, especially in Africa, where both electricity and drinking water are in short supply.

And economic progress in countries lacking in electricity supply is dependent on the modernization of their energy systems, given the strong correlation between the human development index (a combination of education, lifespan and GDP indicators) and annual average electric-power consumption per capita (kWh/capita/year).

Numerous organizations have developed indices and definitions to attempt to characterize and quantify the energy situation of individual countries and provide a meaningful comparison between them. But **there is still no consensus on the definition of Energy Poverty.** Definitions of Energy Poverty generally aim to reflect a lack of access to the modern sources of energy (electricity and non-solid fuels) needed to provide basic energy services like lighting, cooking and heating. However, quantifying such criteria is difficult, as the threshold for energy poverty varies by country. For example, individuals consuming under 1000 kWh per year of modern forms of energy (electricity and non-solid fuel) could be said to be experiencing energy poverty. But this threshold inevitably varies according to local conditions, such as the average annual temperature. Fuel poverty is another commonly used term; it usually means households with access to modern energy services that they cannot afford, but, again, there is no universal definition.

Energy Poverty generally occurs in countries with incomplete or inconsistent data on key economic indicators. Nevertheless, the IEA believes **the deployment of energy for all would have a very limited impact on energy demand (+37Mtoe in 2030) and a small positive impact on climate change (an increase of 70Mt of CO₂ emissions by 2030, but an overall reduction of greenhouse gases of 165Mt CO₂eq in the same period).** The Sustainable Energy for All Initiative identifies a set of action areas to address Energy Poverty, encompassing technological solutions and business regulations. This report considers some of the technologies that may be used to address Energy Poverty and analyses their economics, the progress of existing initiatives and the development of associated regulation.

Energy poverty mostly affects low-income economies and rural areas. Electrification is making progress, but clean-fuel development is stagnating

In the past 15 years, the number of people without access to electricity has been reduced by nearly 35 percent, from ~1.7 billion people to ~1.1 billion people. During that period, about 1.1 billion people gained access to electricity, exceeding global population growth of ~0.6 billion people. India experienced among the fastest rates of electrification, with more than 33 million people on average gaining access every year.

By contrast, access to clean cooking fuels did not progress significantly. **Over the past two decades, the number of people without fuels for clean cooking remained stagnant, at ~2.3 billion.** Globally, access to non-solid fuel is a more acute problem than access to electricity; in almost every country, the transition to electricity has been faster than to clean-cooking fuels.

Around 95 percent of people without access to electricity and non-solid fuels live in sub-Saharan Africa and developing countries in Asia. The 15 worst-affected nations in terms of the proportion of populations experiencing energy poverty are all African; in these countries, the proportion of the population without access to electricity ranges from 65 to 92 percent, while 95-98 percent of people lack access to clean fuels for cooking.

But the largest populations suffering from energy poverty are in India and China. **In 2016, ~239 million people in India did not have access to electricity** (accounting for 22 percent of the global population without electricity access). Combined, **India and China accounted for 1.3 billion people without access to clean fuel** (48 percent of the global population that lacks clean-fuel access).

In general, access to electricity and clean fuel varies according to a country's average economic wealth. In low-income countries, the percentage of the population with access to electricity ranges from 10 percent to 40 percent, compared with 40-80 percent in lower middle-income countries. Only 5-30 percent of people in low-income countries have access to clean fuels, compared with 30-50 percent in lower middle-income countries.

People lacking access to both electricity and clean fuel are predominantly located in rural areas: **87 percent of the total population without access to electricity are in rural areas.** This contrast is even more pronounced in some Asian countries, where 96 percent of people lacking access to electricity are in rural areas. Similar trends are evident for clean-fuel access.

Given existing policies and investments (\$334 billion), the IEA expects a **global reduction in the population lacking access to electricity from 1.1 billion in 2016 to 0.7 billion in 2030.** Between 2030 and 2040, the reduction to attenuate unless further measures are taken. But trends vary by region. For example, while India is expected to achieve universal access to electricity by 2030, access to electricity in Africa is expected to worsen. With populations growing quickly, the number of people without electricity in Africa is projected to rise from 0.6 billion to 0.7 billion by 2040. Universal electrification would require additional estimated investment of \$391 billion in various technologies.

The outlook for access to non-solid fuels is even worse. **The global population lacking access to modern fuel is only expected to fall by 7 percent between 2016 (2.8 billion people) and 2030 (2.6 billion people).** Investment would need to quadruple globally to provide universal access to clean fuel, with ~30 percent of spending allocated to Africa.

Wind, hydro and solar can supply more than enough power to achieve universal access to electricity

Access to electricity can involve a variety of power sources and supply technologies. Global access to electricity has accelerated over the past two decades, with reliance on coal and hydropower increasing.

A wide range of electrification options can help eradicate energy poverty, from small devices deployed locally to utility-scale solutions. All renewable energy sources, including hydro, wind and Solar PV, offer scalable applications in a range of locations, and with a variety of grid connections and power-output capacities.

Electrification solutions range in scope from small, local solutions to mini-grid interconnections and national-grid development. **Grid-extension (transmission and distribution lines) or micro-grid systems are the most cost-effective solutions for electrification in areas where demand intensity is high.** But considerable upfront investment is generally needed, and operation and maintenance costs might also be high, depending on local conditions. For less dense urban areas, remote areas or complex terrains, other “off-grid” solutions might be cheaper but will generally provide less reliable power services.

Electrification strategies and the choice of technologies to underpin them do not just depend on economics. Other important factors include local geography, the environmental impact of the selected technologies, and social acceptance. Criteria that determine cost-effectiveness typically include distance to the existing grid, population size, affordability and generation potential. Off-grid systems, mini-grids or grid extensions all have pros and cons that must be evaluated carefully within the local context.

Harnessing the potential of local renewable resources could end energy poverty in underdeveloped countries. Solar PV and wind have the potential to raise average power consumption per capita to at least 1000kWh per year in poor region, solving global energy poverty without contributions from other energy sources. Small hydropower plants offer another sustainable way of enhancing electrification, especially in rural areas.

The elimination of household air pollution will depend on the use of better technologies and cleaner, more efficient fuels. Eradicating non-clean fuels in cooking would not only reduce dangerous pollution, but would also reduce primary energy demand, since non-clean fuels are extremely inefficient. Modern stove and fuel technologies generate health and economic benefits.

New stove technologies and cleaner liquid and gaseous fuels substantially reduce emissions of CO₂, methane and black carbon, and exposure to the most dangerous air pollutants, like particulates.

Using more efficient fuels can also reduce spending on energy. At present, underdeveloped countries spend an estimated \$37 billion a year on poor-quality energy solutions for lighting and cooking.

International organizations and NGOs have put forward a wide range of innovative solutions for reducing the number of people deprived of clean fuels and the number of deaths from avoidable air pollution.

Policy, regulation support and subsidies are critical in expanding access to clean, reliable, and affordable energy

Energy access is an important element of a sustainable energy-development roadmap for countries with low rates of electrification, along with energy efficiency and renewable energy. **Analysis of national policies indicates that Sub Saharan African countries tend to have a weaker policy and regulation structures than in south Asia.** Successful country programs, such as Vietnam's multiphase electrification plan, demonstrate the need for a considered long-term approach to policy, regulation and incentives.

Energy-access ecosystems consist of multiple stakeholders, each with a crucial role to play. Increasingly, both private and public sectors are dedicating resources and funds to important issues: the efficient deployment of existing solutions at scale, the lack of affordable products and appliances, the lack of financial resources for innovative energy entrepreneurs, and the shortage of local skills and expertise. The international agenda for economic development and many international institutions are also supporting the energy-access ecosystem in relevant countries/regions.

Different delivery models have evolved across different low-income markets. Pay-as-you-go (PAYG) has witnessed rapid growth in Africa and could be adopted in Asia. The PAYG business model allows users to pay for products via embedded consumer financing; customers make a down payment and the remaining repayments are spread over months or years, depending on each customer's financial capacity. Cash and mobile money are the main forms of payment and, as mobile internet penetration increases, PAYG will further enable access to previously under-served markets.

Finally, policy makers should consider industry maturity when designing supporting policy and regulatory frameworks. The choice of policy tools and areas of focus for policy vary according to the ecosystem's maturity, and can be adjusted on a case-by-case basis to achieve the desired socio-economic benefits.

Table of Contents

- 1. Introduction to Energy Poverty: sizing the challenges..... 7**
 - 1.1 Global energy access..... 8
 - 1.2 Benefits of access to modern energy sources 10
 - 1.3 Characterization and definition of energy poverty..... 21
- 2. Global Energy Poverty outlook..... 28**
 - 2.1 Recent evolution of energy poverty.....29
 - 2.2 Current geographic and economic distribution..... 31
 - 2.3 2030 vision and investments required to eradicate energy poverty.....39
- 3. Technology solutions..... 45**
 - 3.1 Available power sources and technology solutions..... 46
 - 3.2 Renewable energy potential of impacted countries.....60
 - 3.2 Clean fuel and cooking technologies..... 63
- 4. Enabling policies and initiatives..... 67**
 - 4.1 Policies and best practice..... 68
 - 4.2 Stakeholders and initiatives..... 77
 - 4.2 Financing and business models..... 83
- Appendix & Bibliography 87**

1. Introduction to Energy Poverty: sizing the challenge

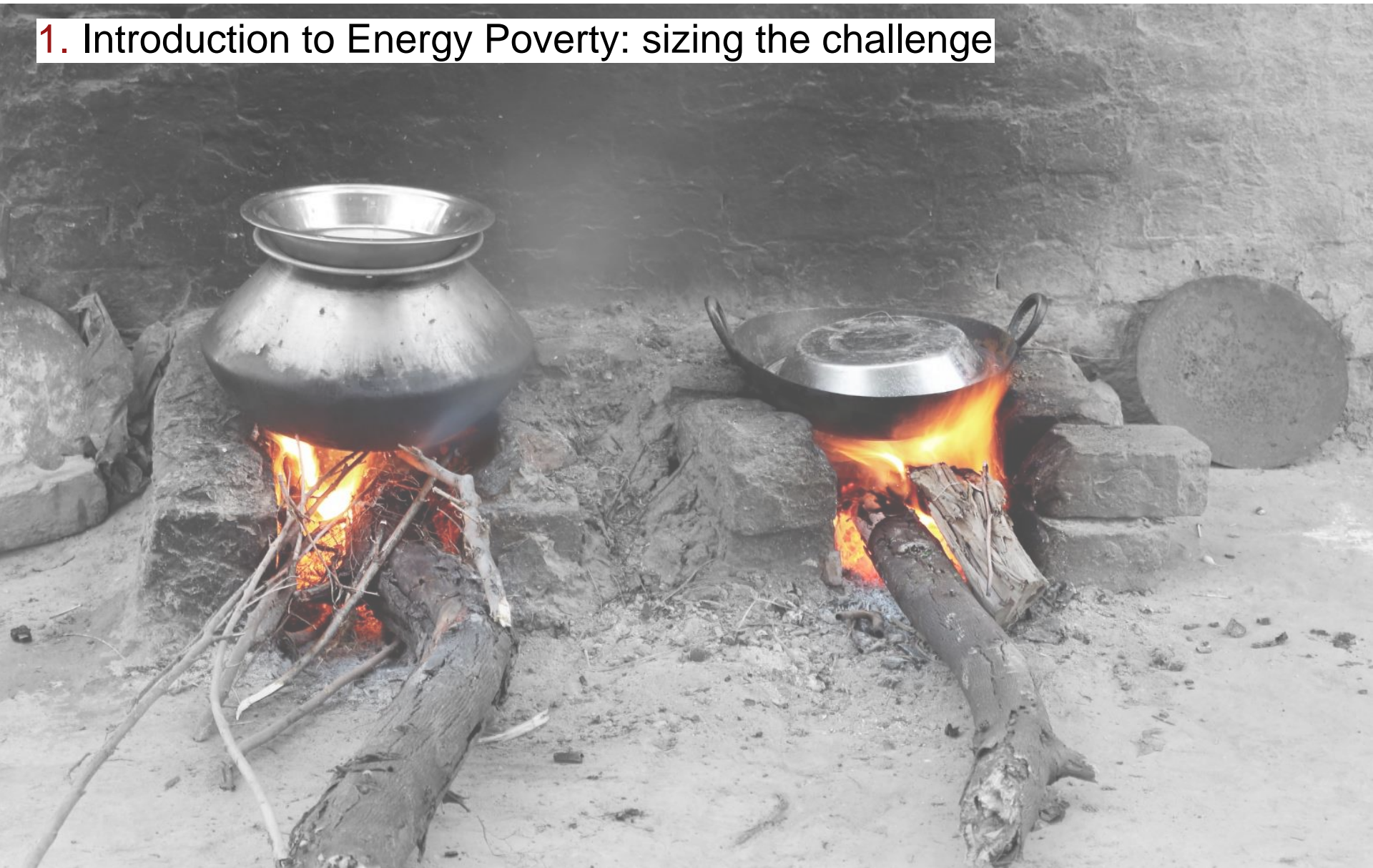

Most of countries with average power consumption less than 2000 kWh per capita are located in Africa and developing Asia and South America

Global distribution of power consumption

kWh per capita per year, 2016

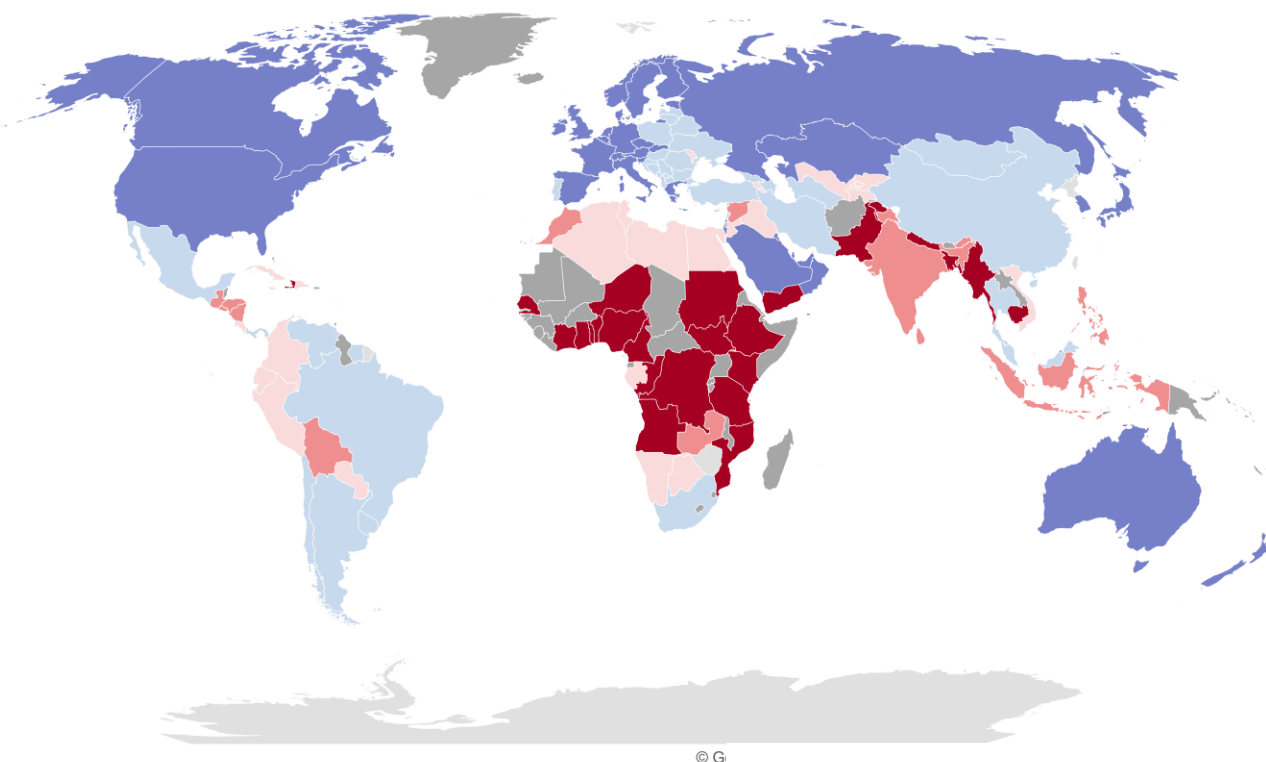

■ No Data ■ Less than 500 ■ 500 - 1000 ■ 1000 - 2000 ■ 2000 - 5000 ■ Higher than 5000

- In whole **Africa** only South African Republic has average power consumption per capita higher than **2000 kWh** per year.
- Situation in developing Asia is not excellent as well where only Thailand has average consumption per capita higher than 2000 kWh per year.
- Parts of South America and large portion of Central America as well as Caribbean show low level of energy consumption per capita.

In 2016, 14% of global population still lacked access to electricity, and 37% to clean fuels

Access to electricity

Million, 2016

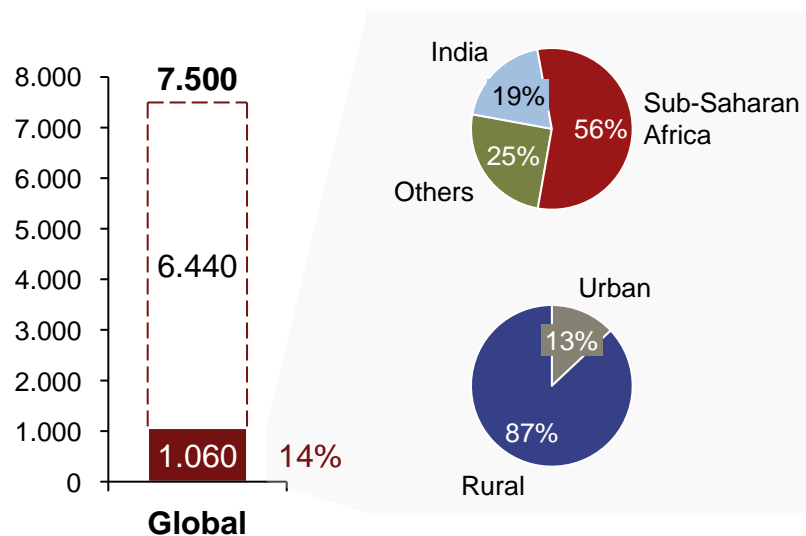

Access to non-solid fuel

Million, 2016

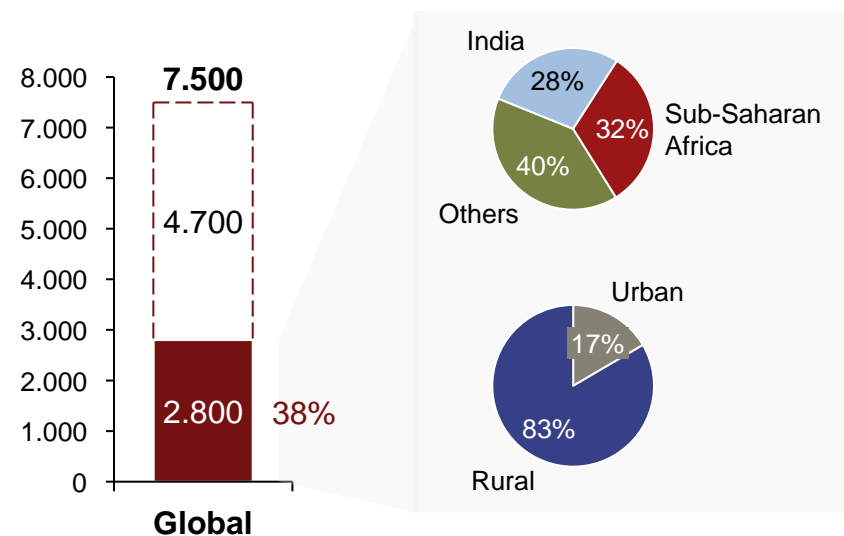

 Population with access  Population without access

According to the IEA, nearly 1.1 billion people live without electricity, and 2.8 billion do not have clean fuels for cooking in 2016, concentrated mostly in rural areas of Sub-Saharan Africa and developing Asia.

Note: The IEA defines energy access as "a household having reliable and affordable access to both clean cooking facilities and to electricity, which is enough to supply a basic bundle of energy services initially, and then an increasing level of electricity over time to reach the regional average".

Source: IEA, World Energy Outlook 2017; World Bank Database

Providing access to clean, sustainable and affordable energy to all is central to the United Nations 2030 Sustainable Development Goals

The 17 Sustainable Development Goals



“Ensure access to affordable, reliable, sustainable and modern energy for all”

Benefits from modern energy access

Not exhaustive

“A well-established energy system supports all sectors: from businesses, medicine and education to agriculture, infrastructure, communications and high-technology. Conversely, lack of access to energy supplies and transformation systems is a constraint to human and economic development.”

Affordable, reliable, clean and sustainable energy helps:

- **“Improve health** through access to clean water, cleaner cooking fuels, heat for boiling water, and better agricultural yields.” “Health clinics with modern fuels and electricity can refrigerate vaccines, sterilize equipment and provide lighting”
- **“Increase household incomes** by improving productivity in terms of saving, increasing output, and value addition, and diversifying economic activity. Energy for irrigation increases food production and access to nutrition”
- **“Provide time for education**, facilitating teaching and learning by empowering especially women and children to become educated on health and productive activities, instead of traditional energy related activities”
- **“Mitigate environmental impacts at the local, regional and global levels**, when based on cleaner fuels renewable energy technologies and energy efficiency
- **“Improve agricultural productivity and land-use** through better machinery and irrigations systems”

Note: Former UN Secretary-General Ban Ki-moon launched Sustainable Energy for All ([SEforALL](#)) in September 2011 as a global initiative that would mobilize action by these diverse actors in support of SDG7’s three core objectives: ensuring universal access to modern energy services; doubling the share of renewable energy in the global energy mix; doubling the global rate of improvement in energy efficiency

Source: United Nation Sustainable Development Goals ([link](#))

Modern energy services are a prerequisite to human well being

Modern energy sources and services

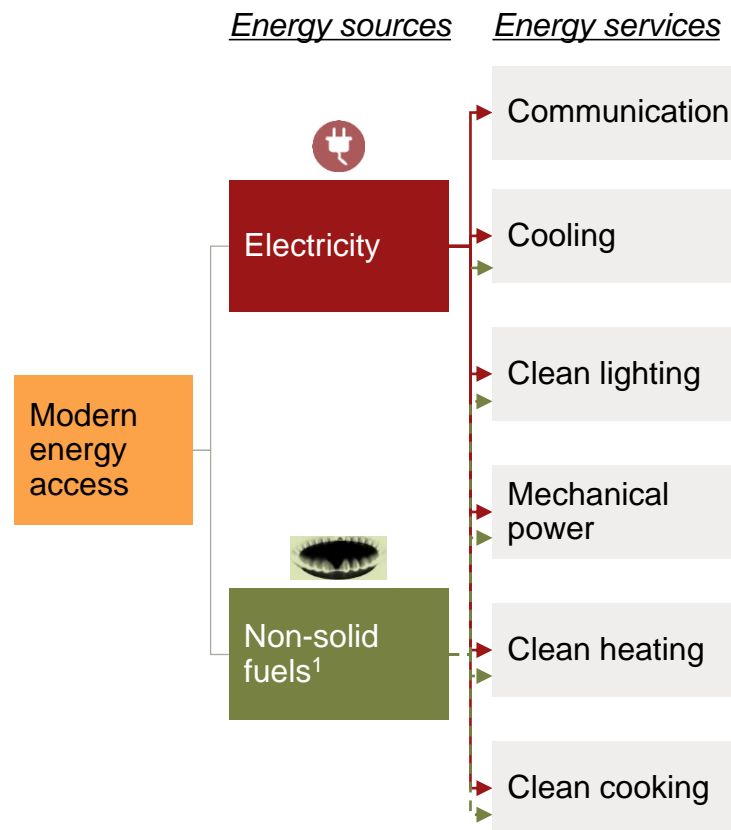

Selected benefits of modern energy access for human well being

- 1 Health**
 - Electrification of dispensaries enables refrigeration and improved sanitization
 - Clean-stove use reduces household air pollution
 - Reduction in use of kerosene lamps reduces risk of fire and damaged eyesight
- 2 Water & food access**
 - Electric pumping, water purification
 - Improvements in agriculture production
- 3 Education & gender equality**
 - Lighting to study in the evenings, access to information technology (web...)
 - Reduced wood fetching time (1h/day per woman in India, up to 2 in Zambia¹)
- 4 Environment**
 - Reduced deforestation from wood gathering
 - Cleaner and less greenhouse-gas-intensive fuels (e.g. LPG² instead of coal and renewables)
- 5 Economics**
 - Time saving (e.g. mechanical transport, communication...)
 - Fuel savings
 - Diversification of economic activities beyond agriculture
 - Extended operating hours for small businesses

1. According to the Global Alliance for Clean Cookstoves.

2. LPG stands for Liquefied Petroleum Gas

Source: A.T. Kearney Energy Transition Institute analysis

Health and safety risks are associated with traditional solid-fuels for cooking and heating

Global premature deaths in 2012

(Million People)

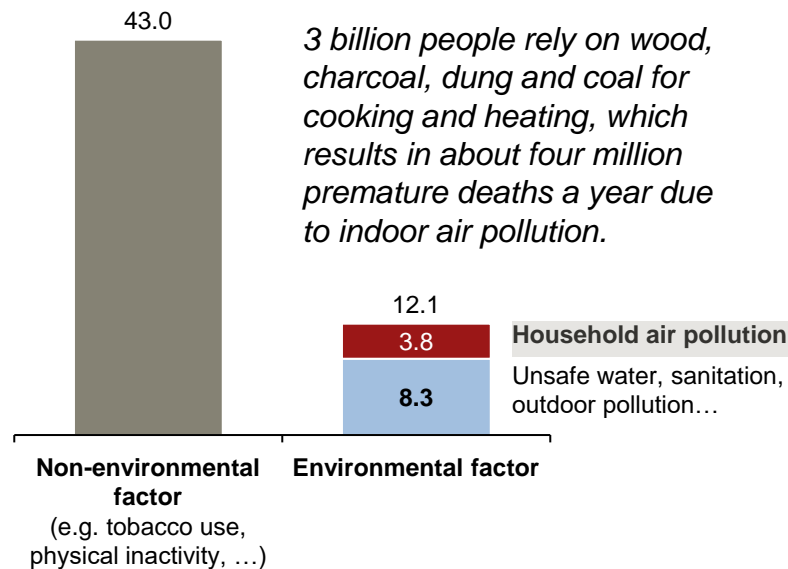

Household air pollution deaths breakdown (%)

By diseases (2012)

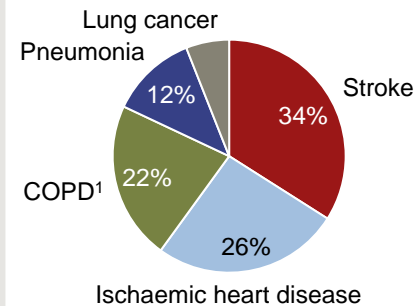

By fuel type (2006)²

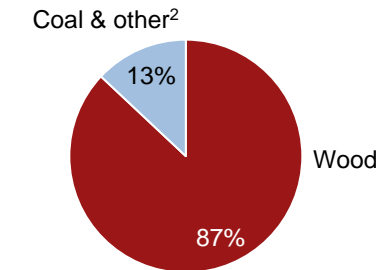

By country (2012)

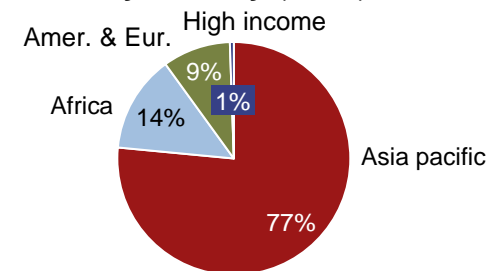

- Household air pollution (HAP) is responsible for about 7% of global premature deaths
- Smoke fumes from incomplete combustion of solid-fuels (especially wood) can exceed acceptable levels for fine particles 100-fold, increasing risks of diseases and cancers, especially among child under five (13% of the premature deaths).
- Other risks includes burns and injuries from open fire and various safety risks during the gathering and collecting of fuel

1. COPD: Chronic obstructive pulmonary disease; 2. Coal includes brown coal, black coal, charcoal and other solid fuels. Despite the outdated reference, the % breakdown still hold true, to date; WHO partially updated its survey in 2014.
Source: WHO (2009), "Mortality and Burden of Disease Attributable to Selected Major Risks"; WHO (2014), "Burden of disease from Household Air Pollution for 2012"; WHO (2016), "Preventing disease through healthy environments"; [link](#)

In 2015, more than 40% of the deaths caused by household pollution occurred in China and India

Premature deaths from household air pollution and population lacking access to clean cooking in the IEA's New Policies Scenario

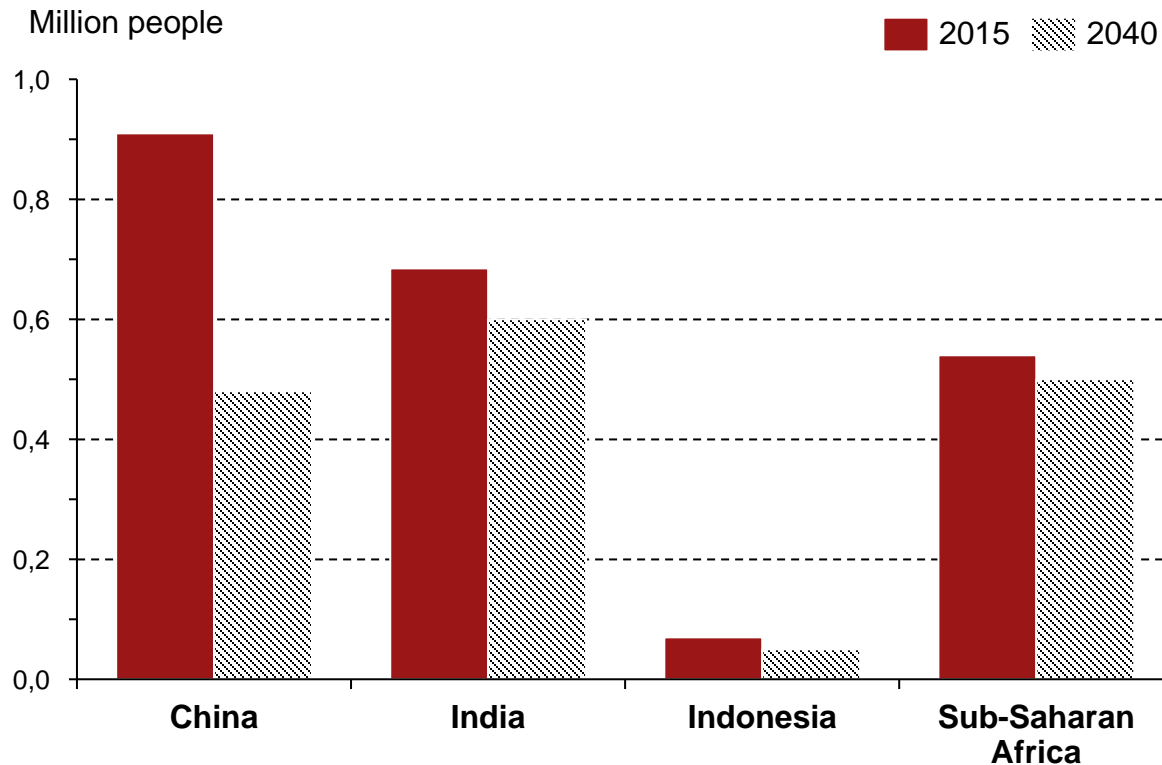

- In 2015 household air pollution caused about **3.8 million deaths**. The IEA (New Policy Scenario) forecasts that situation will not dramatically be improved until 2040 due to the fact that access to clean cooking fuels increases only slowly.
- In China almost 1 million people died due to household pollution related diseases in 2015
- China should account for the biggest progress related to this issue. Progress in South Asia and Sub-Saharan Africa should be in the range of 5-10% only

Switching from solid fuel to cleaner energy would significantly improve household air conditions and therefore reduce premature deaths

Average use of solid fuel for household in various continent

% of population, based on a sample of countries in 2010

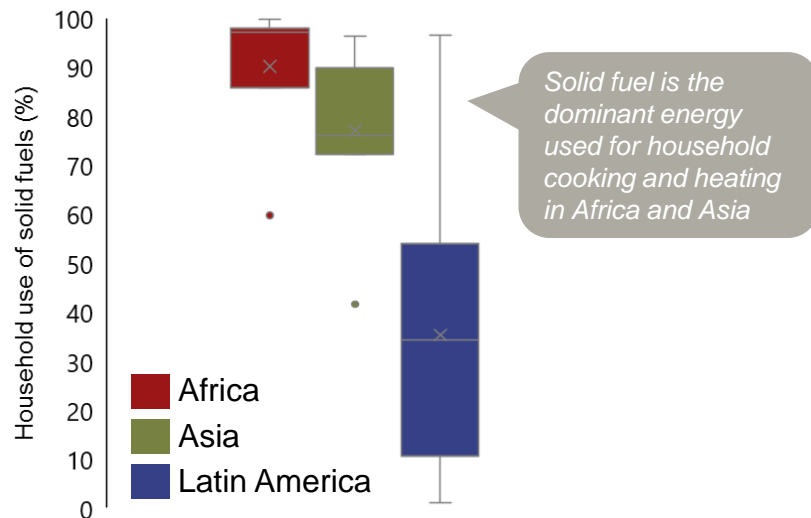

Average annual PM_{2.5}¹ emissions per type of cookstove type

g per household / year

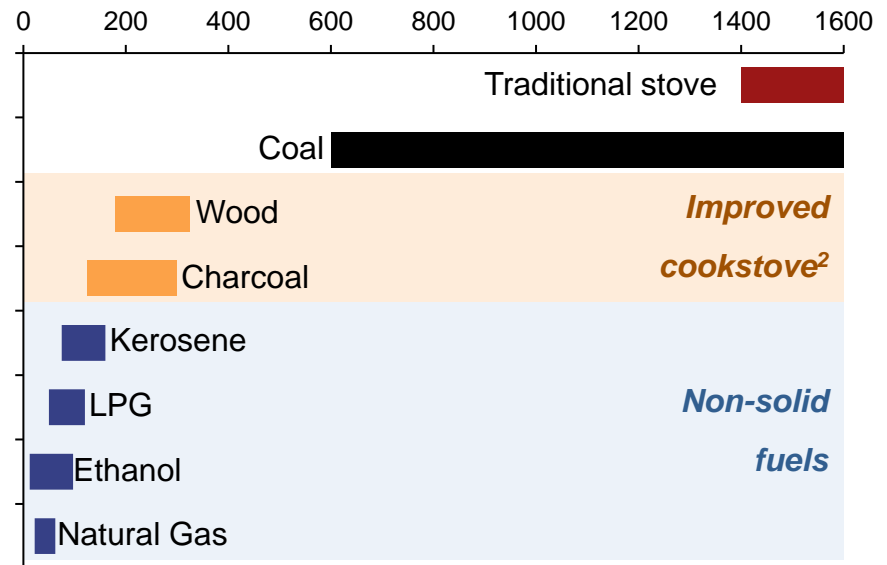

- Household air pollution is mostly created by using kerosene and solid fuels such as wood with polluting stoves, open fires and lamps. The use of wood and charcoal, even in improved cookstove, can emit at least four times more particles (PM_{2.5}) than natural gas. According to IEA, providing clean cooking and electricity to all would reduce the number of premature deaths by 1.8 million.
- The WHO 2005 guideline for PM_{2.5} are 10 µg/m³ (annual mean) and 25 µg/m³ 24-hour mean.

Note: (1) Particulate Matter (PM_{2.5}) are all kind of pollutants (combustible particles, organic compounds, metal, ect.) with diameter < 2.5 microns. PM_{2.5} is a concern for people's health when levels in air are high. (2) stove with higher efficiency or lower level of pollution, generally with a chimney or closed combustion chamber.

Source: based on WHO International Agency for Research on Cancer, (Vol 95, Household use of solid fuels and high-temperature frying - 2010); Global Alliance for Clean Cook Stoves, 2018 ([link](#)); IEA, Energy Access Outlook 2017, from Poverty to Prosperity; IEA, WEO Special Report 2016 Energy and Air Pollution; A.T. Kearney Energy Transition institute Energy Poverty 14

Power generation is essential to increase access to freshwater

Energy use for various processes in the water sector (kWh/m³)

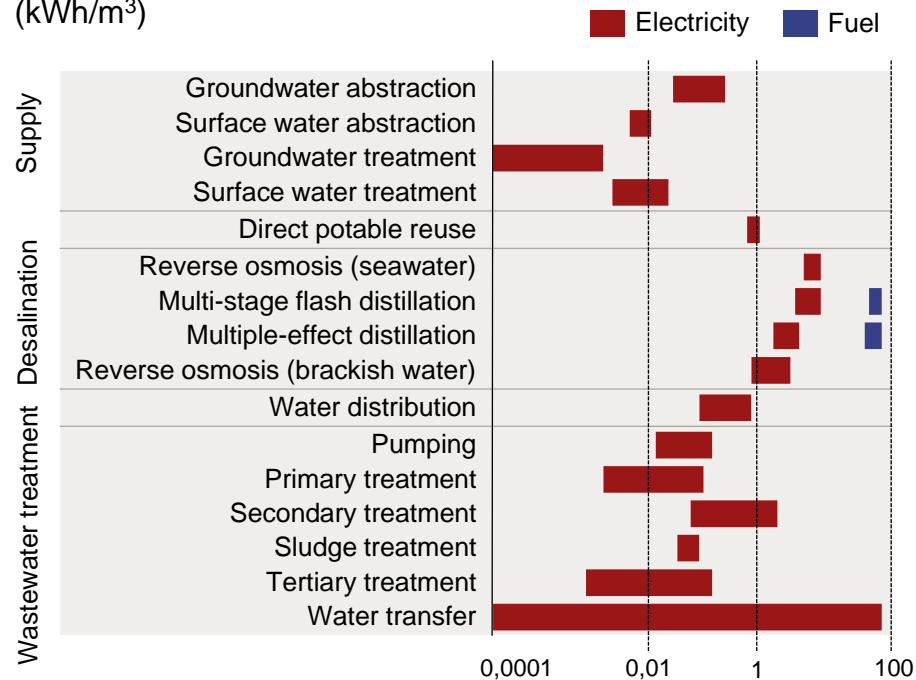

- Power generation is essential to freshwater supply, particularly where energy poverty coincides with freshwater scarcity.

Total population without access to improved¹ drinking-water source (%, 2015)

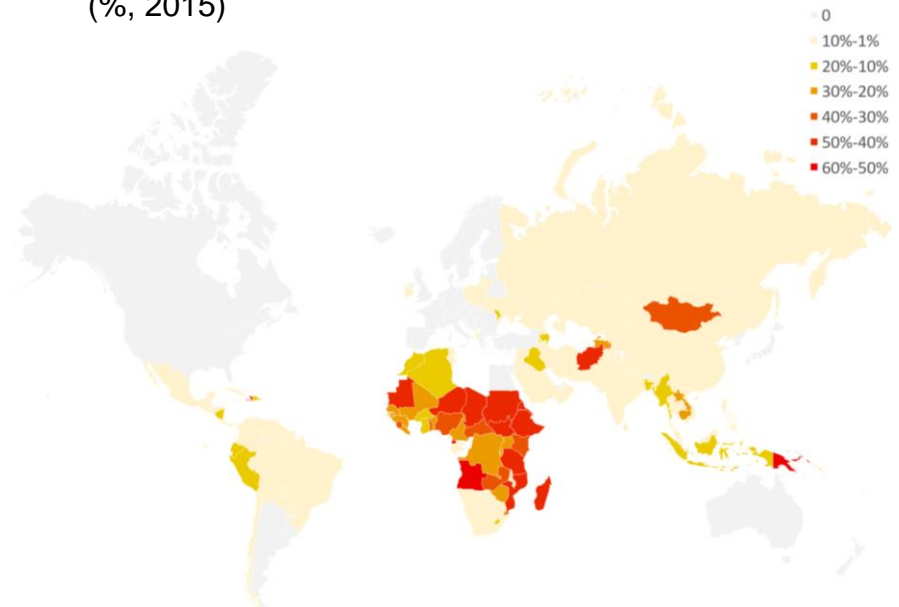

- Only 71% of the global population have water that is considered safely managed. Access to drinking water is particularly critical in Africa, where more than 40% of the population do not have access to improved drinking water in many countries.

Note: (1) An "improved" source is one that is likely to provide "safe" water, such as a household connection, a borehole, etc.

Source: IEA, *Water Energy Nexus - Excerpt from the World Energy Outlook 2016*; FAO, FAO. 2016. AQUASTAT Main Database - Food and Agriculture Organization of the United Nations (FAO). Website accessed on June 2018 ([link](#)); A.T. Kearney Energy Transition Institute, Introduction to the Water-Energy Challenge

Water energy and land are closely interrelated and should be considered as a whole

Water-Energy-Land nexus

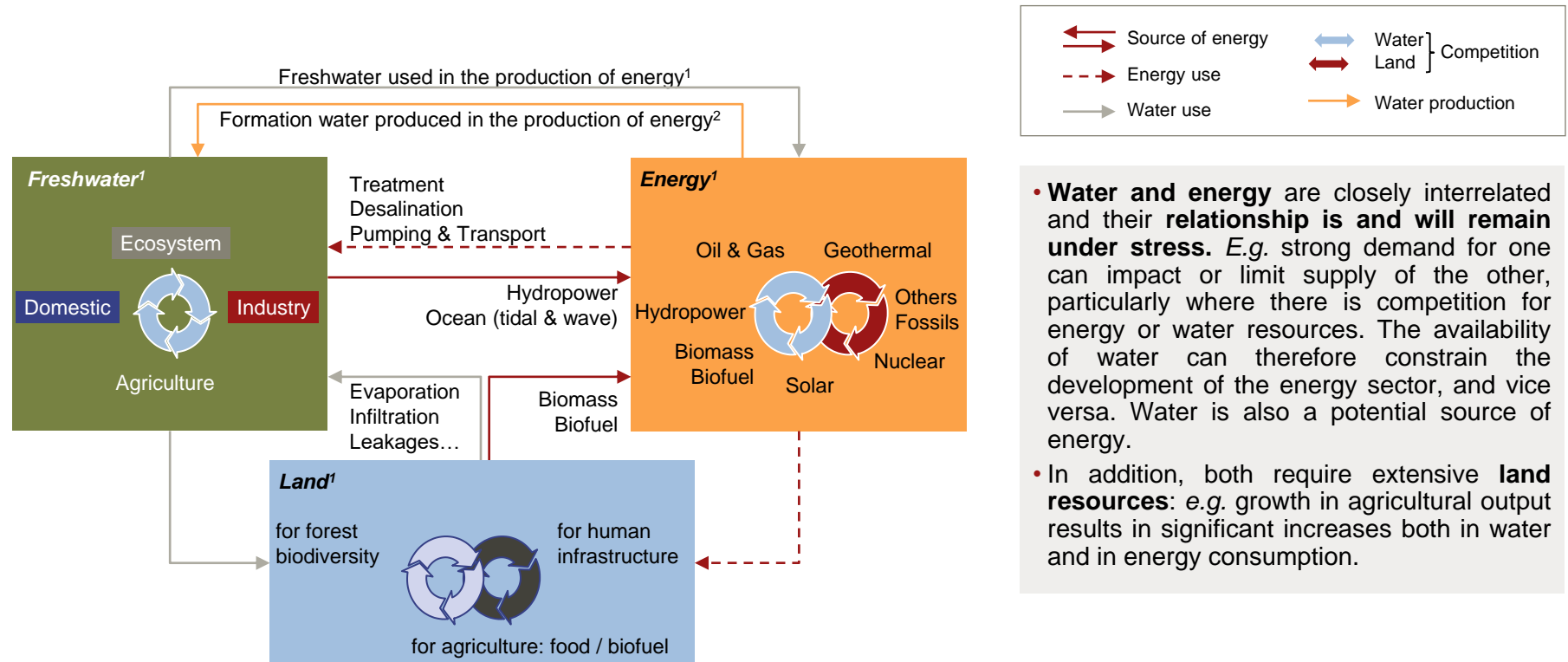

1. Each subsection competes with the others for freshwater supply, contributing to global stress; 2. Oil and gas companies produce a large quantity of saline formation water during the exploration and production of a field. Mature depleted fields require either water or gas injection to maintain production (enhanced oil/gas recovery).

Source: European report on development (2012), "Confronting scarcity: Managing water, energy and land for inclusive and sustainable growth"; World economic forum (2011), "Water security, the water-food-energy-climate nexus"; A.T. Kearney Energy Transition Institute analysis

Energy poverty impacts directly and indirectly education and gender equality

Source of education inequality

- **Children perform better at school if they have access to electricity.** They are:
- **More likely to finish primary school** (according to Brazilian, rural statistics , UNESCO).
- **Less likely to need to repeat school years** (one hour of daily study by children aged 3 to 12 reduces the probably of needing to repeat a school year 1.6 percentage points).
- Unelectrified households often cite education as a benefit of electrification, it seems that, especially in poor families, electricity is as often used by children to do schoolwork.

Sources of gender inequality

- **Women spend more time gathering solid fuels than men.** Households dedicate an average of 1.4 hours a day to collecting fuel, time that could be better spent on education and other more profitable activities; according to the IEA, this amounts to over 1 billion of hours that could be used for other activities
- **Women are more exposed than men to household air pollution**, as they generally spend more time cooking and suffer greater exposure to particulate emissions from traditional stoves (four hours a day on average in rural South Asia).
- “In Sri Lanka, women estimate that lighting gives them about two extra hours of useful time a day, which they can invest not only in better domestic management and childcare, but also in resting, socializing, watching television, and sometimes in income-generating activities. For the first time, women get full control of part of their daily schedule.” (1)
- Electrification increases the level of female employment in newly electrified communities

Environmental impact of traditional biomass is often ignored in climate-change discussions as it is wrongly considered “renewable”

Average fraction of biofuel that is non-renewably harvested⁴

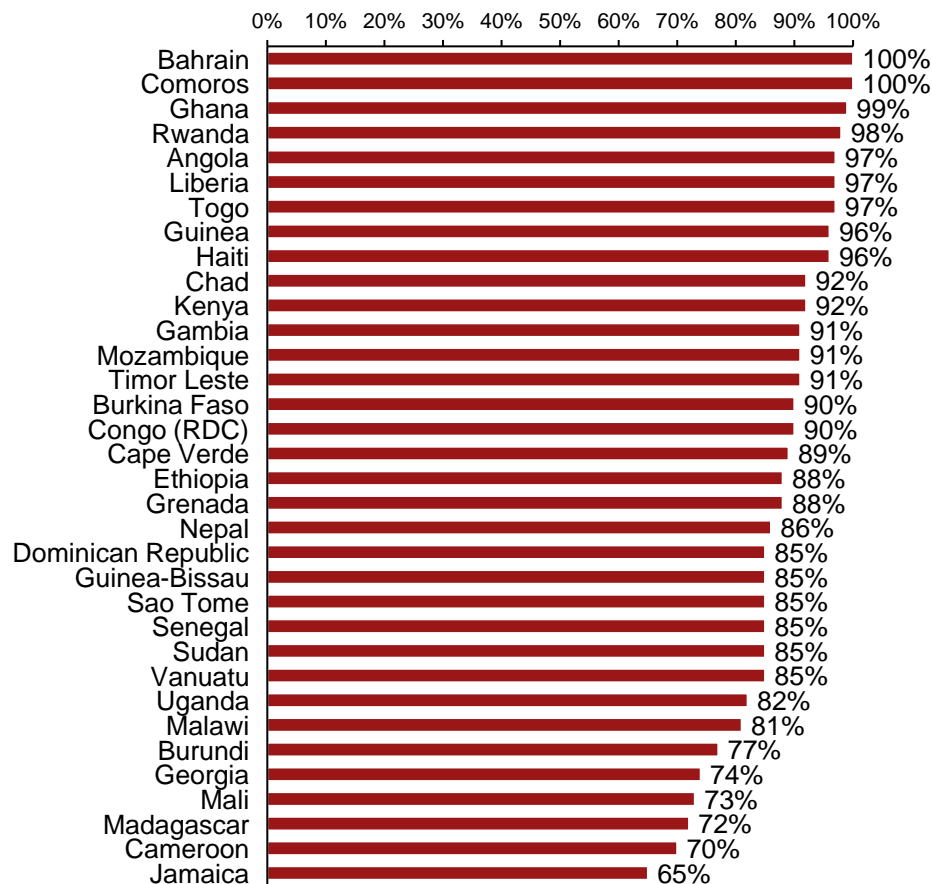

- Solid household fuels account for about 10-15% of global primary energy use. At the same time, **nearly 18% of global CO₂ emissions are attributed to primary energy use in the residential sector**. About half¹ comes from traditional biomass (wood, charcoal, crop residues...), a share much higher in developing countries². Households therefore collectively represent a significant opportunity for mitigating climate change.
- Yet, despite emitting about **1.3 billion tonnes** of CO_{2eq} each year³, traditional biomass used for cooking is often ignored in climate-change discussion, as it is often wrongly considered “renewable”.
- A renewable biomass has to be harvested no faster than it is regrown, in order to balance CO₂ emitted during combustion with CO₂ captured via photosynthesis growth.
- Crop residues, animal dung or standing tree stocks are generally renewable. In many instances however, especially in the least developed or rapidly developing nations, biomass is generally **non-renewably harvested** (see left exhibit), leading to deforestation and net CO₂ emissions.

1. 11.2% of global final energy use in 2015; 2. In Africa, 80% of the population relies on biomass;

3. Grupp (2004), “Domestic cooking appliances in developing countries”; 4 least developed countries and small island states only

Source: CDM Executive Board, <https://cdm.unfccc.int/DNA/fNRB/index.html> ; WHO (2015), Health in the green economy; IEA (2011), World Energy Outlook.

Even if renewably harvested, solid biofuels used in traditional cooking stove emit more GHG than modern liquid or gaseous fossil-fuel stoves

Global warming Commitment of various household fuels stoves in India

gCO₂-equivalent¹ per MJ heat delivered to the food

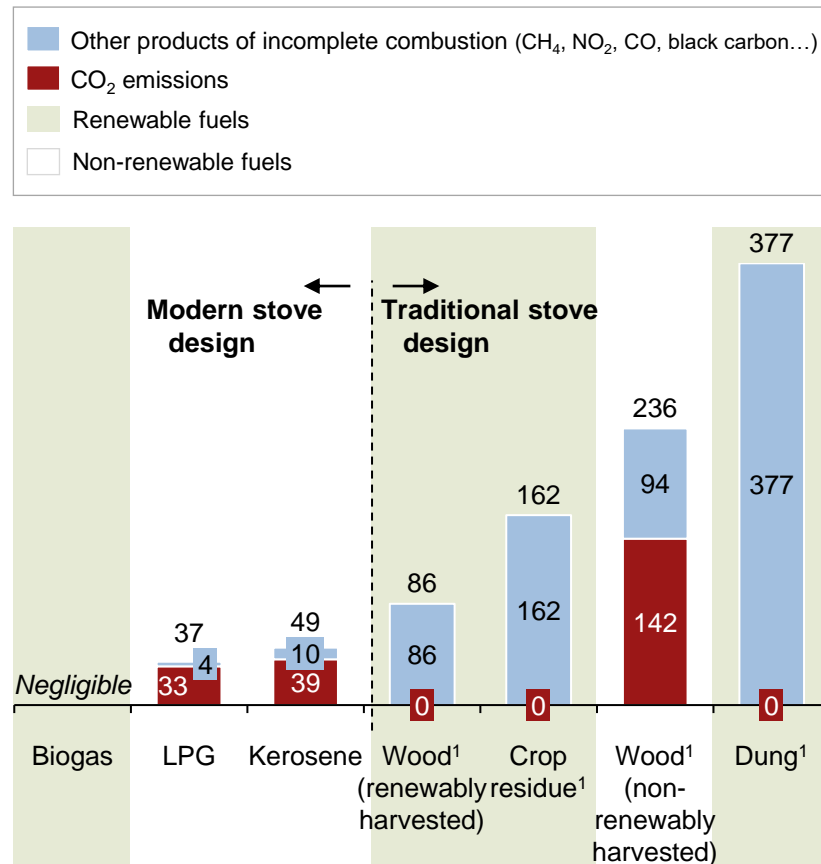

- **In addition to CO₂, incomplete combustion of biomass and coal in traditional stoves releases very high levels of other pollutants**, called "products of incomplete combustion". These include:
 - Methane, a very potent greenhouse gas
 - Carbon monoxide, nitrous oxides, and black-carbon particles. These substances have proven global-warming effects, but are not yet regulated by any climate-change convention
- Overall, **the greenhouse impact of a meal cooked on a traditional stove with solid biomass can actually be greater than with modern fossil fuels** (liquid or gaseous), even if renewably harvested. Liquid or gaseous fuels can indeed be premixed with the air supply to achieve high combustion efficiency in simple small-scale devices.
- It is hoped that recent design improvements to advanced biomass systems, like small-scale gasifier stoves and biogas stoves, will result in **better combustion efficiency, dramatically reducing the output of products of incomplete combustion by up to 90 percent**, compared with traditional stoves (refers to section 3.2)
- According to the IEA (2017), **the deployment of the Energy for All case would have a very limited impact on the energy demand (+37Mtoe in 2030) and a small positive impact on climate change (+70Mt of CO₂ emissions, but overall reduction in GHG of -165Mt CO₂eq in 2030).**

Note: GHG: Greenhouse Gases; LPG: Liquefied petroleum gas; Global warming potential measured over a 20 years horizon;

(1) Average stove design in India in 2000

Source: Smith et al. (2000), Greenhouse implication of household stoves: An analysis for India. WHO (2015) Health in the green economy

Socio-economic development is strongly correlated to energy access, and in particular electricity

Human development index (HDI) versus electricity consumption in 2016

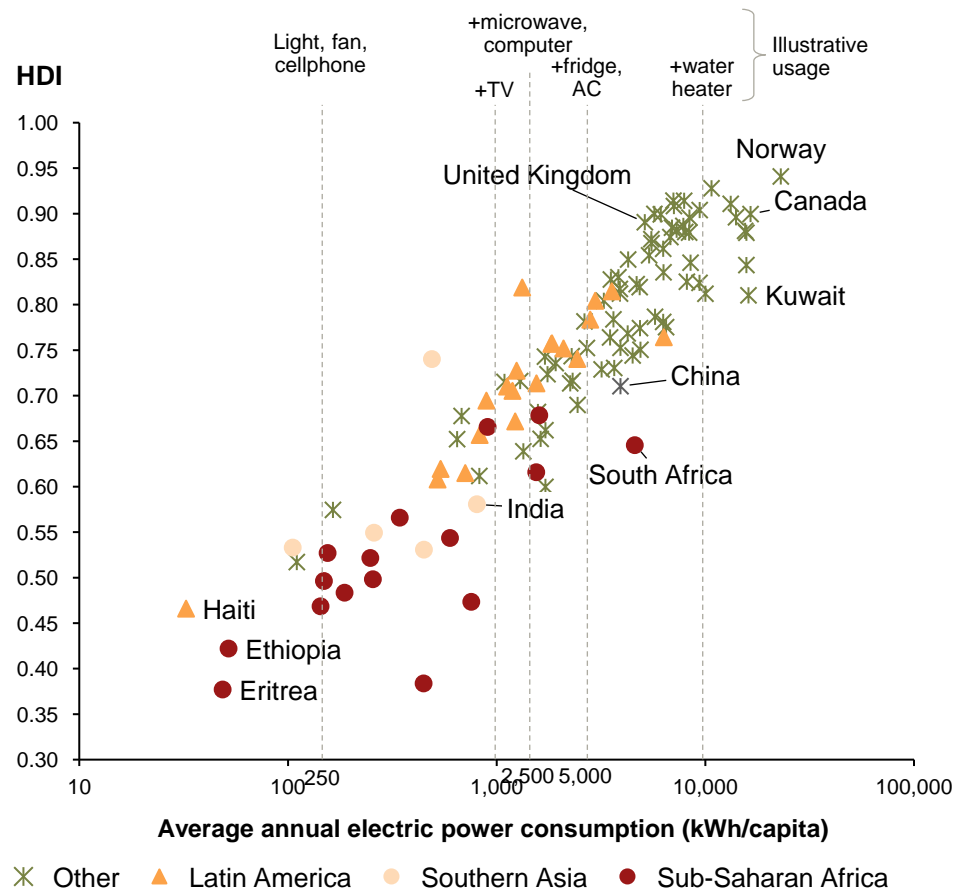

- The **Human Development Index (HDI)** is a composite statistic that incorporates life expectancy, education and per capita income indicators.
- A country scores higher in the HDI as **lifespan** lengthens, **education** improves, and **GDP per capita** rises.
- HDI is closely correlated to electricity consumption per capita per year in the case of all countries.
 - The correlation holds true for GDP per capita too
 - The correlation begins to break down when per capita power consumption starts to exceed 5000MWh/year, highlighting the importance of energy efficiency in richer industrialized nations.
- In many developing countries, low average electricity consumptions are compounded by low electrification rate, further restricting socio-economic development to a limited share of the population.
- According to the d. Light basic energy access level is set to be at 250 kWh/capita/year for rural area, and 500 kWh/capita/year, for urban area.

Energy poverty is complex concept often associated to the challenges to access energy

Key challenges to get access to energy

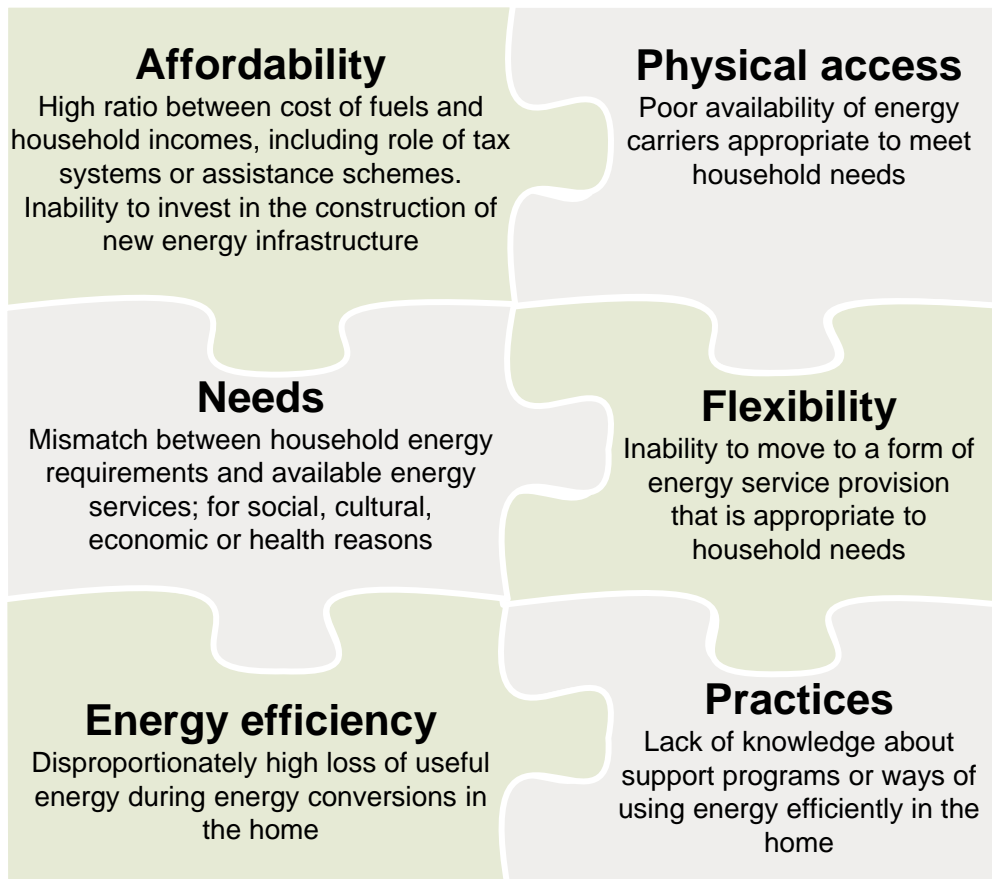

- According to the European Commission, “**energy poverty is a complex and multi-dimensional concept** that is not adequately captured or measured in empirical reality by any single quantitative indicator.”
- Energy poverty is often assessed using various issues related to energy access: Affordability, Physical access, Energy Needs, Flexibility service, efficiency of Energy services and lack of Energy knowledge (Practices).

There are several ways to characterize degrees of energy access, including incremental levels and the multi-tier approach

Incremental levels

Level 1: Basic human needs	Level 2: Productive uses	Level 3: Modern society needs
<ul style="list-style-type: none"> • Electricity for lighting, health, education, communication and community services (50-100 kWh per person per year) • Modern fuels and technologies for cooking and heating (50-100 kgoe¹ of modern fuel or improved biomass cook stove) 	<ul style="list-style-type: none"> • The use of electricity, modern fuels and other energy services to improve productivity, e.g.: <ul style="list-style-type: none"> – Agriculture: water pumping for irrigation, fertilizer – Commercial: agricultural processing, cottage industry – Transport: fuel 	<ul style="list-style-type: none"> • The use of modern energy services for more complex needs: <ul style="list-style-type: none"> – Domestic appliances – Increased requirements for cooling and heating – Private transportation • Electricity usage is about 2,000 kWh per person per year

Multi-tier approach (for electricity)

	Tier-0	Tier-1	Tier-2	Tier-3	Tier-4	Tier-5
Technology supplying the required energy	No electricity	Solar lanterns	Stand-alone systems	Mini-grids with limited supply or poor grid connection	Unreliable grid with limited supply	Reliable grid with 24-hour supply
Attributes of access to electricity	Continuous spectrum of improving energy supply attributes including adequacy, availability, reliability and quality of supply					
Feasible energy applications	No electricity	Continuous spectrum of improving energy supply applications including lighting and radio (tiers 1) to refrigeration, heating (tiers 5)				

Various approaches have been developed to assess the level of energy poverty or energy development

Illustrative

Multidimensional Energy Poverty Index (MEPI)

Dimension	Indicator (weight)
Cooking	• Use of modern cooking fuel (0.2)
	• Indoor pollution (0.2)
Lighting	• Access to electricity access (0.2)
Services provided by means of household appliances	• Ownership of household appliance (0.13)
Entertainment/Education	• Ownership of entertainment or educational appliance (0.13)
Communication	• Ownership of telecommunication means (0.13)

- Developed by the **Oxford Poverty & Human Development Initiative (OPHI)**, the **Multidimensional Energy Poverty Index (MEPI)** measures energy poverty through the prism of energy **deprivations** affecting a member of a household.
- The index consists of **5 dimensions**, each representing a modern energy service: Cooking, Lighting, Services from household appliances, Entertainment/education and Communication. Each indicator has a **relative weight** and an **associated deprivation cut-off**. The formula is the product of the headcount ratio of people identified as energy poor and their average intensity of deprivation.

The Energy Development Index (EDI)

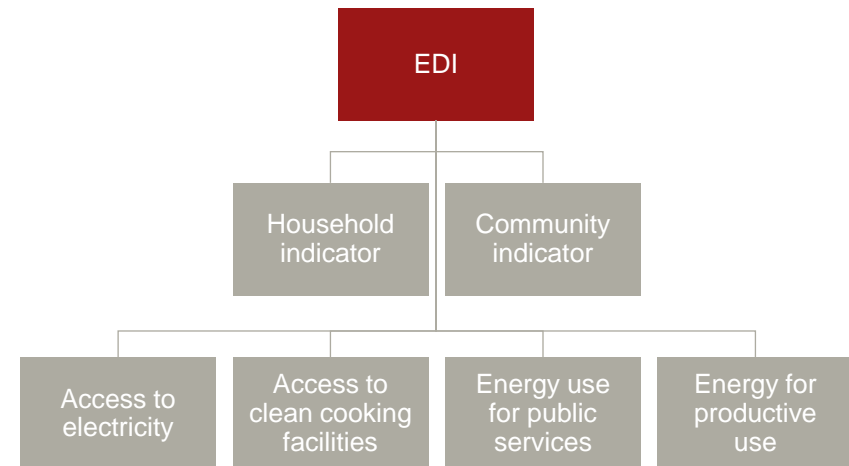

- Published in the WEO 2004, the IEA used the **Energy Development Index (EDI)** until 2012 (WEO 2012). It measured energy development at the **household and community levels**. The household level focuses on **access to electricity** and **clean cooking facilities**; the **community level** focuses on **access to energy for public services and for productive use**.
- In the terms of **productive energy use**, the focus is on modern energy use as part of **economic activity**, for example, agriculture, textiles and other manufacturing.

The MEPI and EDI indicators enable a country-by-country analysis based on various facets of energy poverty and other factors

Illustrative

Countries with the highest MEPI results

MEPI, 2009

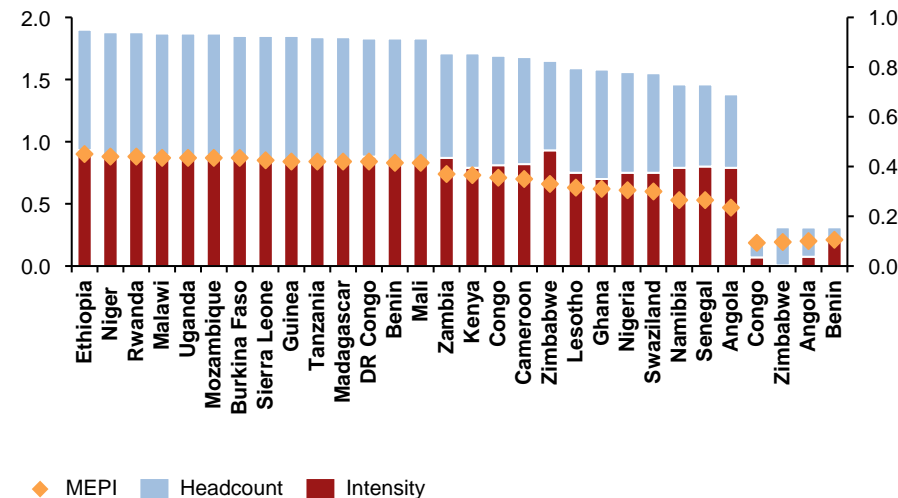

Countries with the lowest EDI scores

EDI, 2012

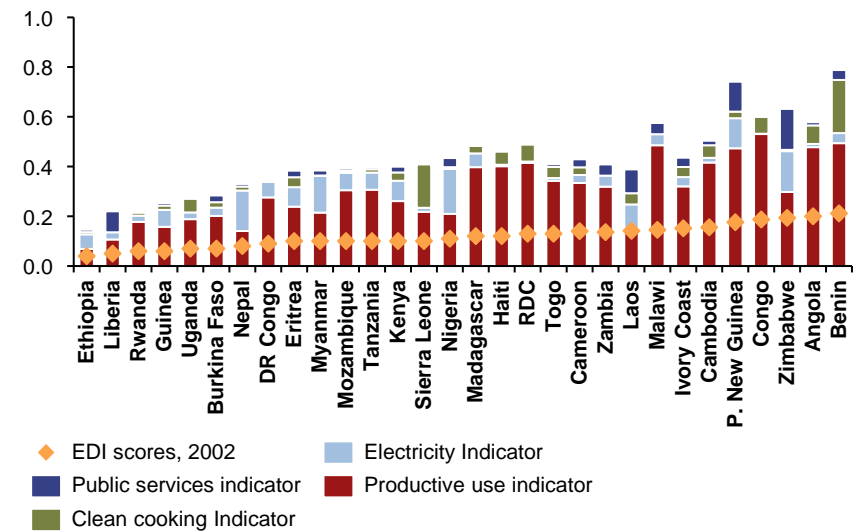

- The **MEPI** classifies countries according to degree of energy poverty. The classification ranges from countries characterized by **acute energy poverty (MEPI > 0.7)**, to countries with a low degree of energy poverty (MEPI < 0.3). The countries with the most severe energy poverty are in **Sub-Saharan Africa**. Of these, **Ethiopia, Niger, Rwanda, Malawi and Uganda have the highest MEPI**, with a **headcount ratio and intensity of energy poverty close to 1**. High MEPI indicates that a very large share of the population is energy poor and that segment of the population is severely affected.

- Sub-Saharan Africa** also records the lowest **EDI** scores, with **Ethiopia, Liberia, Rwanda, Guinea and Uganda** scoring particularly poorly. Nigeria records a low EDI score, reflecting scant use of modern fuels in cooking and electricity in public services. Countries in **developing Asia** achieve more varied rankings, although Nepal and Myanmar have particularly low scores. Countries with low EDI rankings tend to achieve poor results in terms of **clean-cooking** and **public-services** indicators.

Multilateral organizations, countries and researchers define energy poverty in a variety of ways

Example of energy poverty definitions

IEA ²	“ Lack of access to electricity and reliance on traditional biomass fuels for cooking”
UNDP ³	“ Inability to cook with modern cooking fuels and the lack of a bare minimum of electric lighting for reading or for other household and productive activities at sunset.”
EU Energy Poverty Observatory	“Energy poverty occurs when a household suffers from a lack of adequate energy services in the home.”
France (ONPE ⁴)	“A person who encounters in his/her accommodation particular difficulties to have enough energy supply to satisfy his/her elementary needs . This being due to the inadequacy of resources or housing conditions.”
Austria (E-Control)	“A household is considered energy poor if its income is below the at-risk-of poverty threshold and, at the same time, it has to cover above-average energy costs.”
England (DECC ⁵)	“ A household income is below the poverty line (taking into account energy costs) and their energy costs are higher than is typical for their household type.”
Asian Development Bank	“The absence of sufficient choice in accessing adequate, affordable, reliable, high-quality, safe and environmentally benign energy services to support economic and human development.”
Bouzarovski S. et al (2015)	“ Inability of a household to secure a socially- and materially-necessitated level of energy services in the home.”

Note: (1) According to EU Energy Poverty Observatory terms ‘energy poverty’ and ‘fuel poverty’ have the same meaning; (2) International Energy Agency; (3) United Nations development Program; (4) L’Observatoire National de la Précarité Énergétique; (5) Department of Energy and Climate Change;

Source: UNDP (2010), Human Development Report 2010; European Commission (EC) (2015), Selecting Indicators to Measure Energy Poverty;

In the report, Energy Poverty means insufficient access to electricity and non-solid fuels and is characterized in terms of energy thresholds

Characterization of energy situations

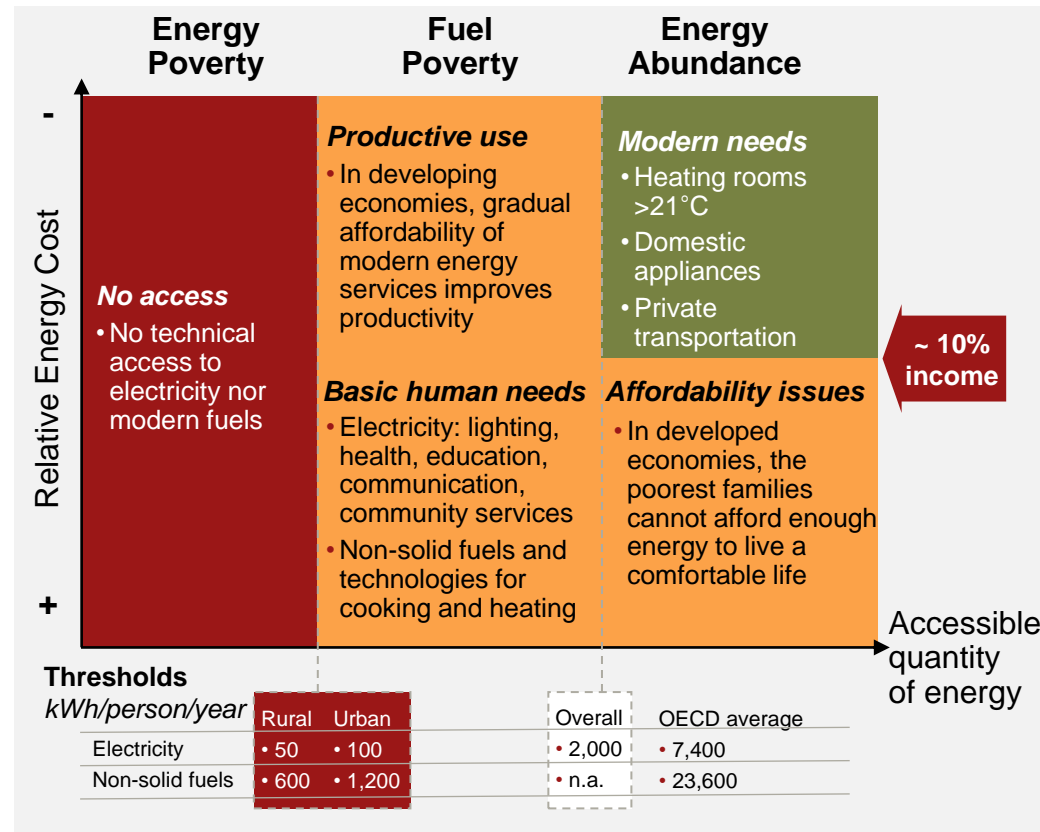

Definitions and scope

Factbook Scope

Energy poverty is defined as a lack of access to modern sources of energy (electricity and non-solid fuels¹), which are needed to provide modern energy services (clean lighting, clean cooking, clean heating or cooling, telecommunication, mechanical power).

Fuel poverty refers to households that have access to modern energy services but cannot afford enough of them to live a comfortable life.

- This concept is relative to the standard of living of the country
- It has been mostly applied in cold-climate economies
- No single definition is predominant

Energy abundance refers to households that have access to modern energy sources (electricity and non-solid fuels¹) and that can afford them in quantity corresponding to modern needs

1. Modern or non-solid fuels include liquid fuels (e.g. kerosene, ethanol) and gaseous fuels (e.g. natural gas, LPG, diesel, biogas). They are cleaner than solid-fuels including biomass (wood, dung), coal and lignite, typically used in traditional cooking.

Source: Li *et al* (2014), "Energy poor or fuel poor: What are the differences?"; IEA (2012), "WEO - Methodology for energy access analysis"; Hills (2012), "Getting the measure of fuel poverty: final report of the Fuel Poverty Review"; 2009 (UNDP), "The energy access situation in developing countries"; A.T. Kearney Energy Transition Institute analysis

Sustainable Energy for All has identified a set of action areas to address energy poverty

Action areas covered in the FactBook⁽¹⁾

Technology Solutions

Modern cooking appliances and fuels		Providing access to modern energy services for those who lack clean and efficient equipment such as stoves and fuels
Distributed electricity solution		Providing access to electricity through off-grid, micro- and mini-grid solutions, including targeted applications for productive uses
Grid extension	Grid infrastructure and supply efficiency	Extending the electricity grid and increasing the efficiency of energy generation, transmission, and distribution
	Large scale renewable power	Accelerating the build-out of grid-connected renewable energy solutions and the associated transmission and distribution infrastructure

Technology Solutions is covered in Section 3 of the FactBook

Business and Regulation is addressed in Section 4

Business & Regulation

Business model and technology innovation	Developing new approaches to overcome barriers that have impeded the development of sustainable energy services and technologies in the past, ensure the affordability and reliability of technology and foster innovation
--	---

- The **Sustainable Energy for All** is an initiative involving governments, the private sector and civil society
- It was launched by the UN Secretary-General Ban Ki-moon in 2011. It has three objectives to be achieved by 2030:
 - ensure universal access to modern energy services,
 - double the global rate of improvement in energy efficiency and
 - double the share of renewable energy in the global energy mix.
- Its activities include national coordinating committees, international energy forums or country level actions to spur investment

Note: (1) The remaining 6 actions areas, not included in the scope of this factbook, are: industrial and agricultural processes, transportation, buildings and appliances, energy planning and policies, finance and risk management, capacity building and knowledge sharing
 Source: Sustainable energy for all (2012), "A Global Action Agenda, Pathways for Concerted Action toward Sustainable Energy for All"; Sustainable energy for all website (<http://www.se4all.org/our-vision/our-objectives/>)

2. Global energy poverty outlook

In the last fifteen years, the number of people without electricity access has been reduced by nearly 35%, despite global population growth

Evolution of the global population without electricity access

Million people, 2000 - 2016

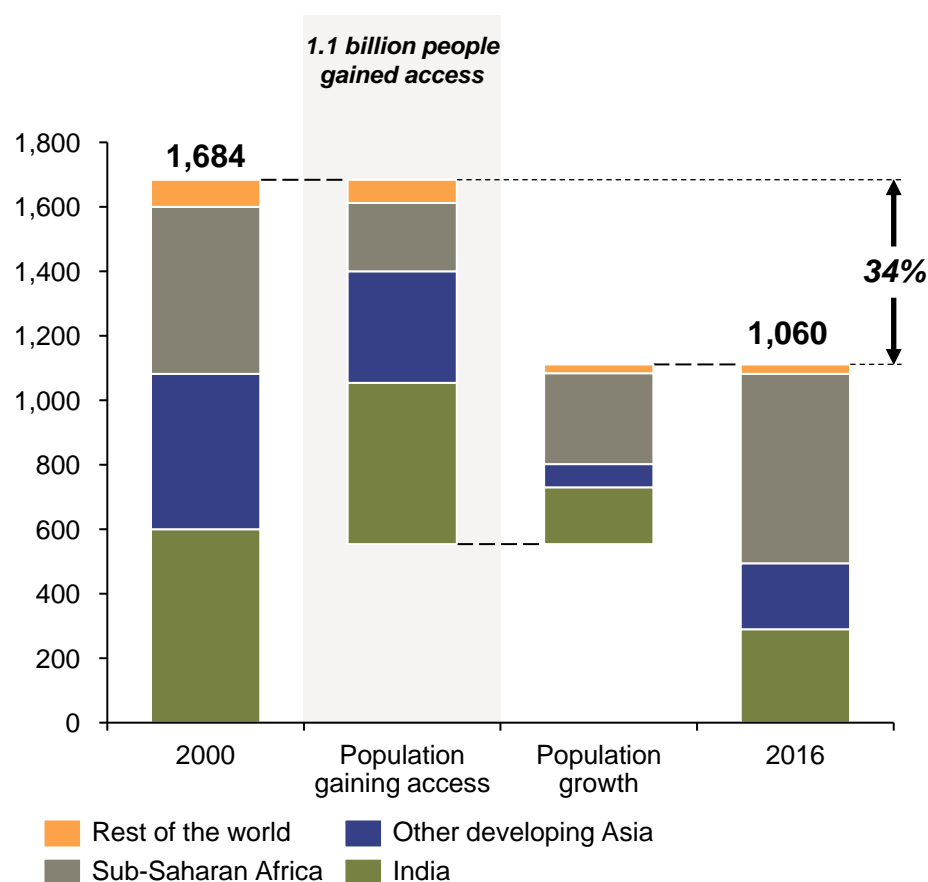

- Today, almost **1.1 billion people** do not have access to electricity facilities; about **14 percent of global population**.
- Since 2000, 1.1 billion people gained access to electricity and the global population grew by 557 million people. As a result, **the proportion of the global population without access to electricity fell by 34 percent**.
- **India** experienced one of the fastest electrification rates, providing electricity to an additional 500 million people over the 16 years. **Other developing countries in Asia** also registered significant progress, and the Asia's electrification rate is now 89 percent, compared with 67 percent in 2000.
- **Sub-Saharan Africa is the only region exhibiting a negative trend**, with the number of people without electricity access increasing by 70 million people over the period.

The number of people without access to clean cooking facilities has stagnated in the past 15 years

Evolution of the global population without access to clean cooking facilities

Million people, 2000 - 2016

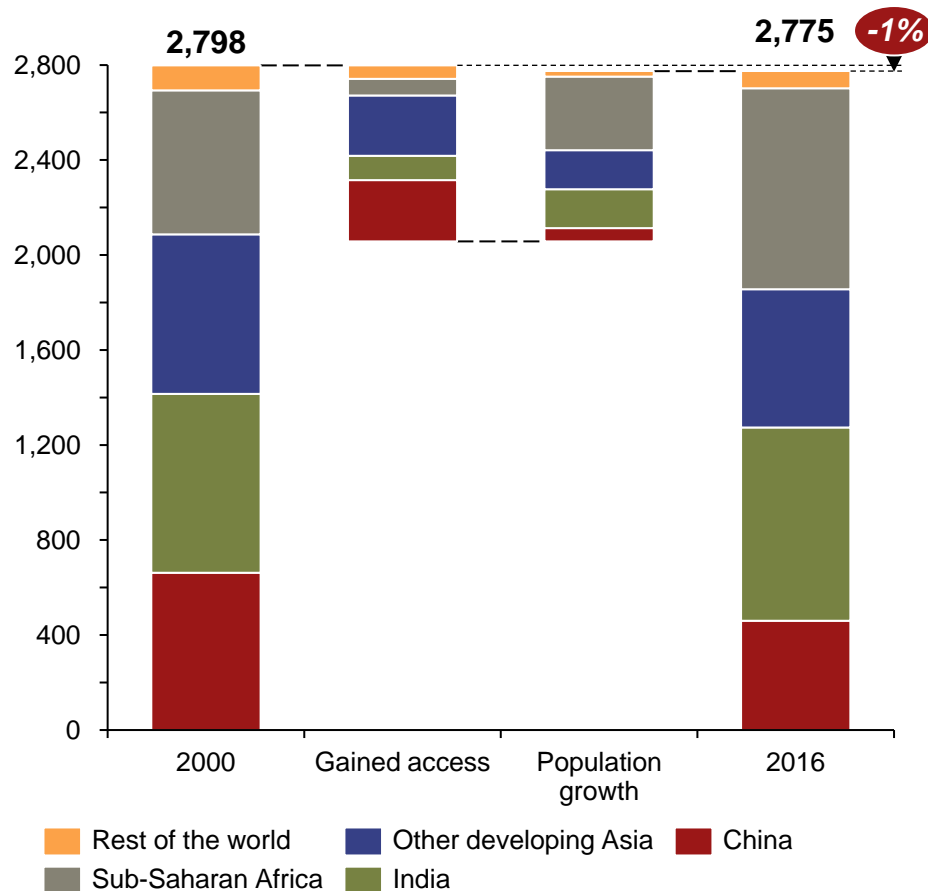

- Today, about **2.8 billion people do not have access to clean-cooking facilities**. A third of the world's population therefore still relies on solid biomass to cook meals.
- Over the past 16 years, the situation has improved in **China** and in **other Asian countries**. Since 2000, many people have switched from solid fuels to kerosene, LPG and natural gas
- However, **in India and in Africa**, the number of people without clean-cooking facilities rose. In sub-Saharan Africa, **240 million more people were** reliant on biomass for cooking **in 2016 than in 2000**.

Note: (1) Developing Asia: Bangladesh, Brunei, Cambodia, China, India, Indonesia, Korea DPR, Malaysia, Mongolia, Myanmar, Nepal, Pakistan, Philippines, Singapore, Sri Lanka, Thailand, Viet Nam, Afghanistan, Laos and Pacific nations; (2) World total includes OECD and Eastern Europe/Eurasia

Source: IEA, WEO Energy Access Outlook 2017; A.T. Kearney Energy Transition Institute

Globally, the lack of access to non-solid fuel is more acute than the absence of access to electricity

Access to electricity versus non-solid fuel of countries

% of population, million of people (2016)

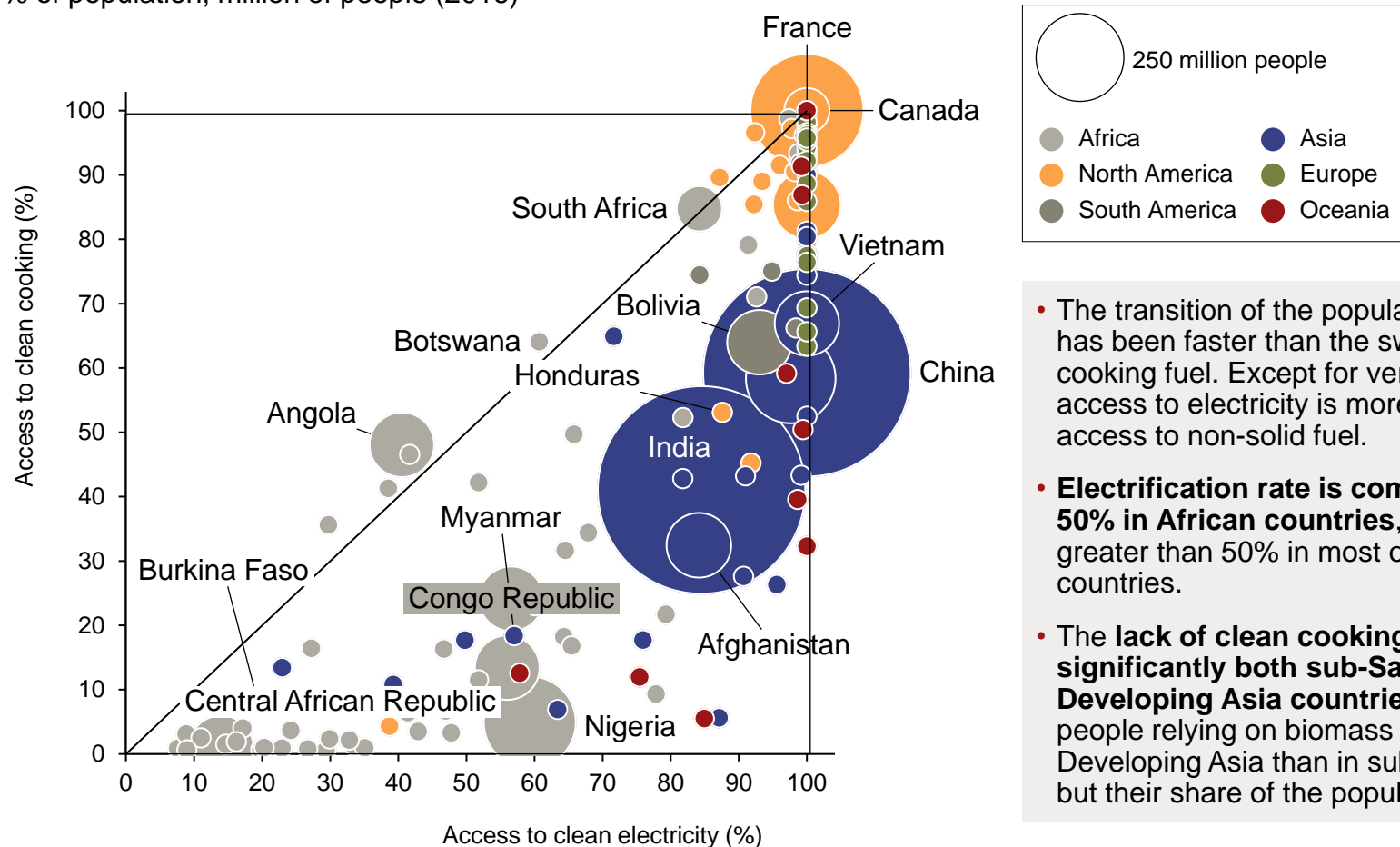

- The transition of the population to electricity has been faster than the switch to clean cooking fuel. Except for very few countries, access to electricity is more developed than access to non-solid fuel.
- **Electrification rate is commonly below 50% in African countries**, while this rate is greater than 50% in most of developing Asia countries.
- **The lack of clean cooking fuel affect significantly both sub-Saharan Africa and Developing Asia countries.** The number of people relying on biomass is larger in Developing Asia than in sub-Saharan Africa, but their share of the population is lower.

Around 95% of the world's people without access to electricity and non-solid fuel access live in sub-Saharan Africa and in developing Asia

Distribution of energy access in the world

Million people, 2016

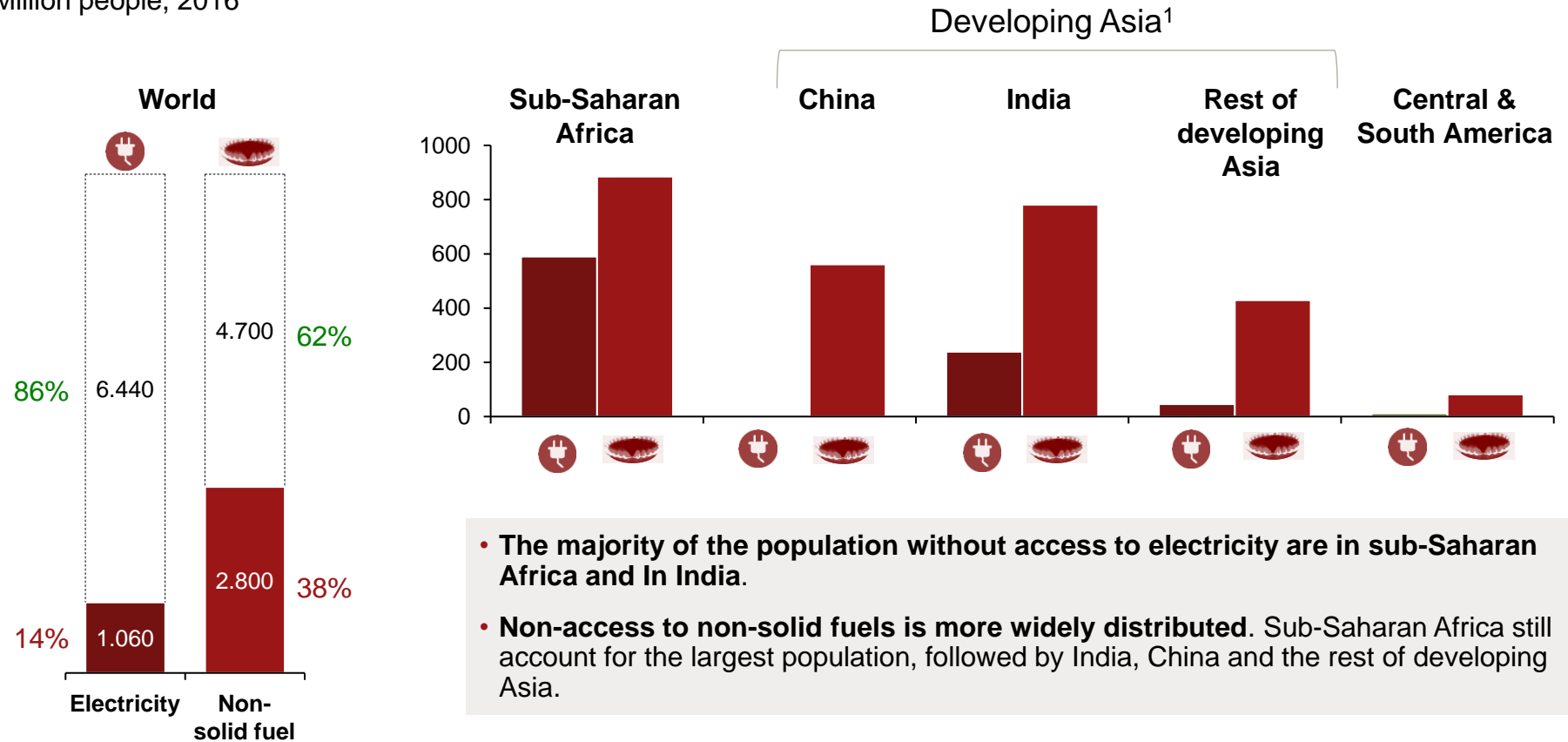

- The majority of the population without access to electricity are in sub-Saharan Africa and In India.
- Non-access to non-solid fuels is more widely distributed. Sub-Saharan Africa still account for the largest population, followed by India, China and the rest of developing Asia.

Population with access (white bar) Population without access (red bar)

Note: (1) Developing Asia: Bangladesh, Brunei, Cambodia, China, India, Indonesia, Korea DPR, Malaysia, Mongolia, Myanmar, Nepal, Pakistan, Philippines, Singapore, Sri Lanka, Thailand, Viet Nam, Afghanistan, Laos and Pacific nations. (2) World total includes OECD and Eastern Europe/Eurasia
 Source: IEA, WEO Energy Access Outlook 2017; A.T. Kearney Energy Transition Institute

Most deeply affected countries are located in sub-Saharan Africa

Population without access to electricity 
% population, 2016

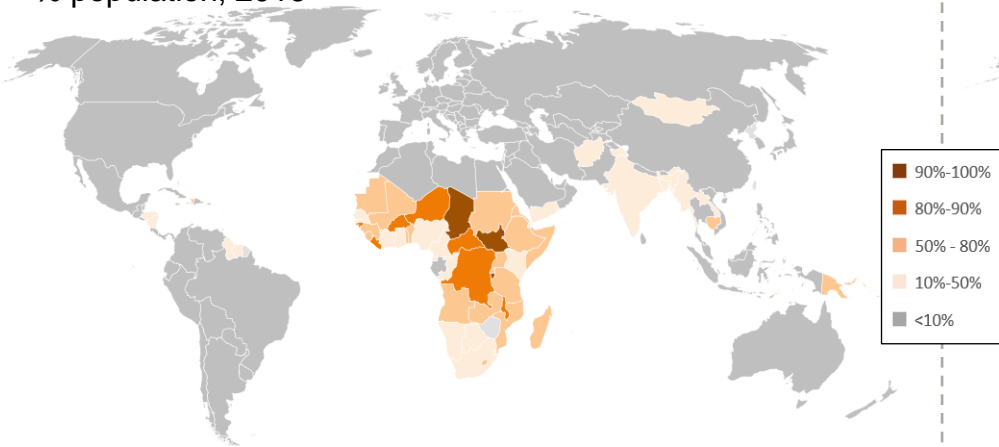

Population without access to clean fuel 
% population, 2016

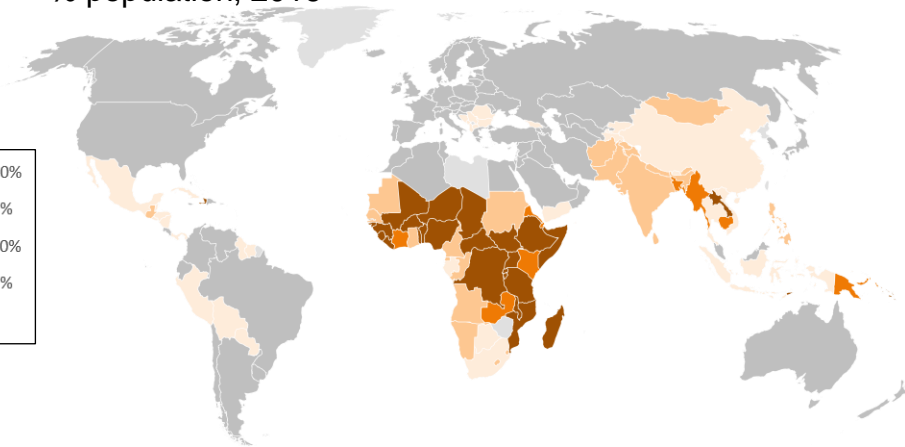

Top 15 countries

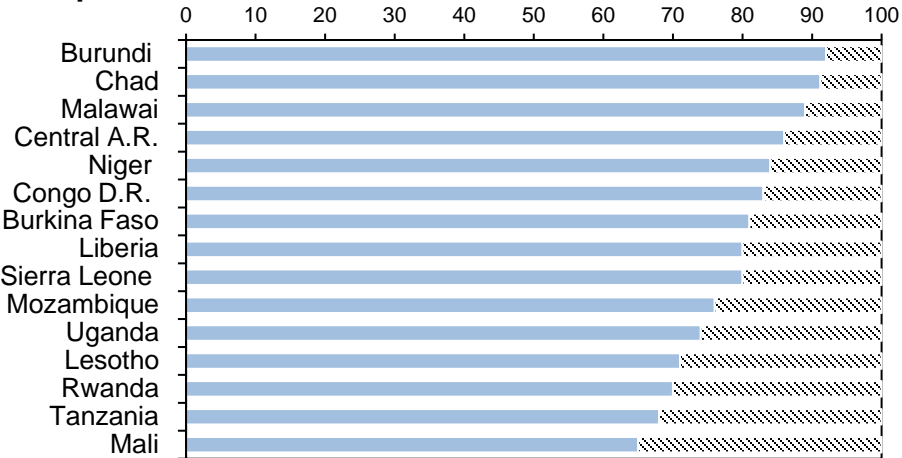

Top 15 countries

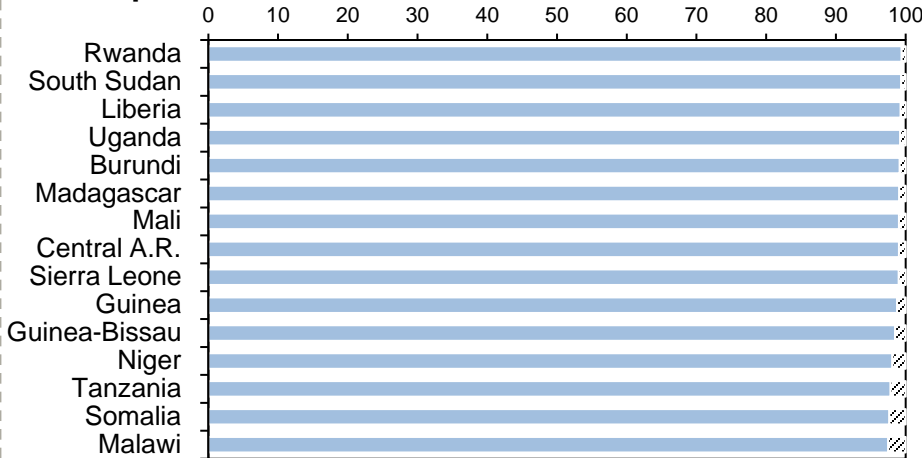

India and China hold the largest populations in situation of energy poverty

Population without access to electricity

Million people, 2016

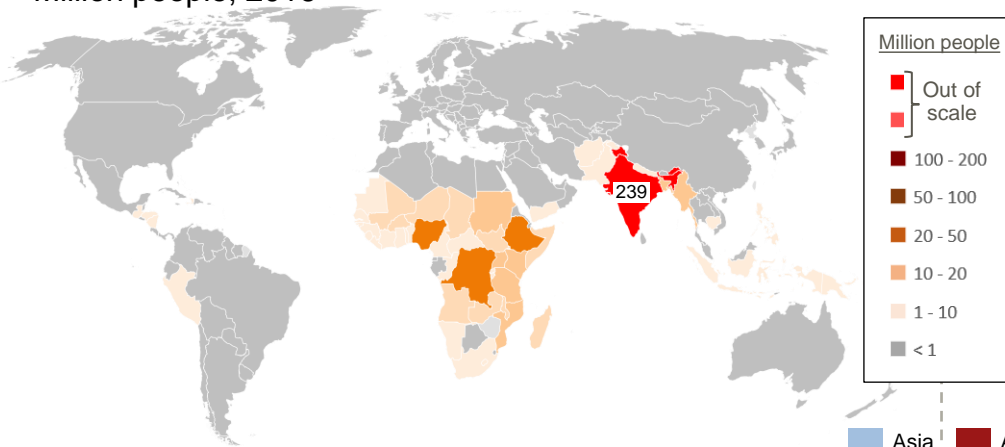

Population without access to clean fuel

Million people, 2016

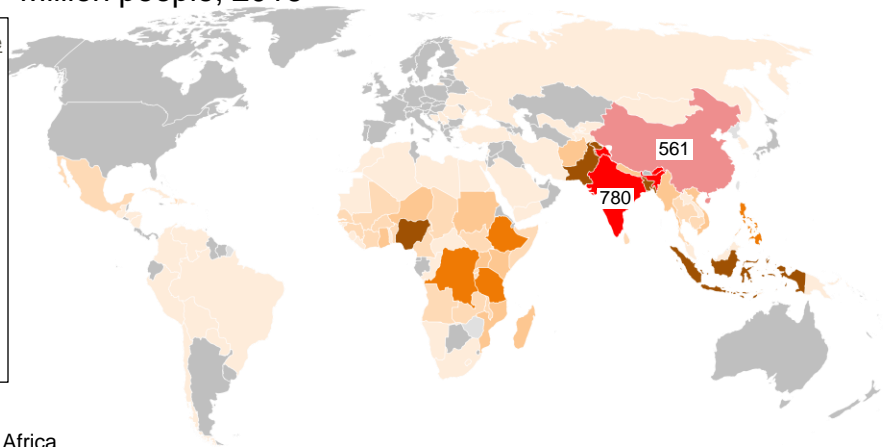

Top 15 countries

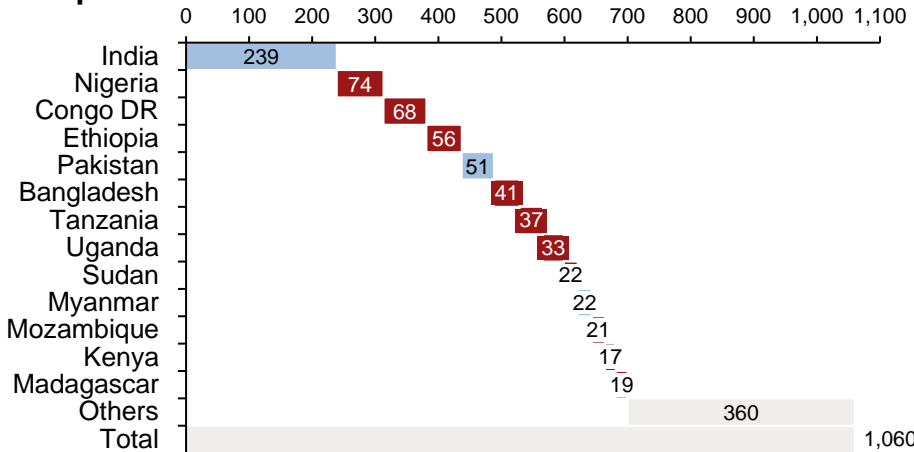

Top 15 countries

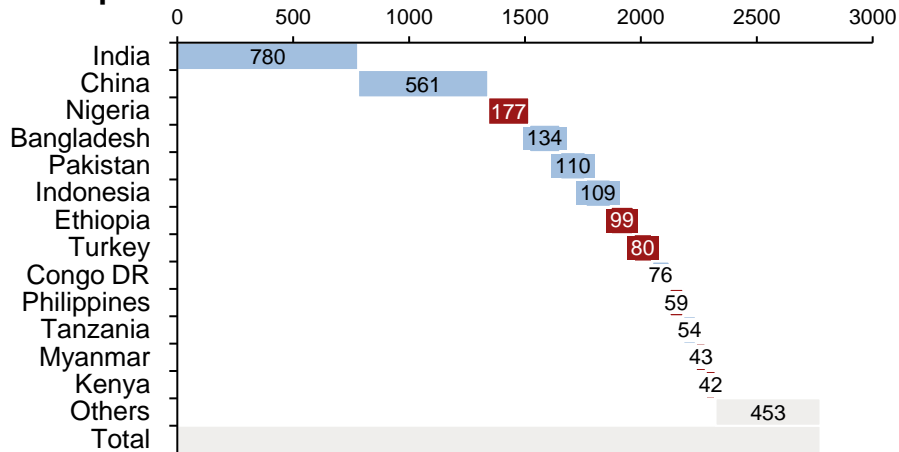

In general, access to electricity varies with the average economic wealth of the country

Cumulative population lacking access to electricity per country economic wealth

% of people per county vs. total population of country; average national income (2017)

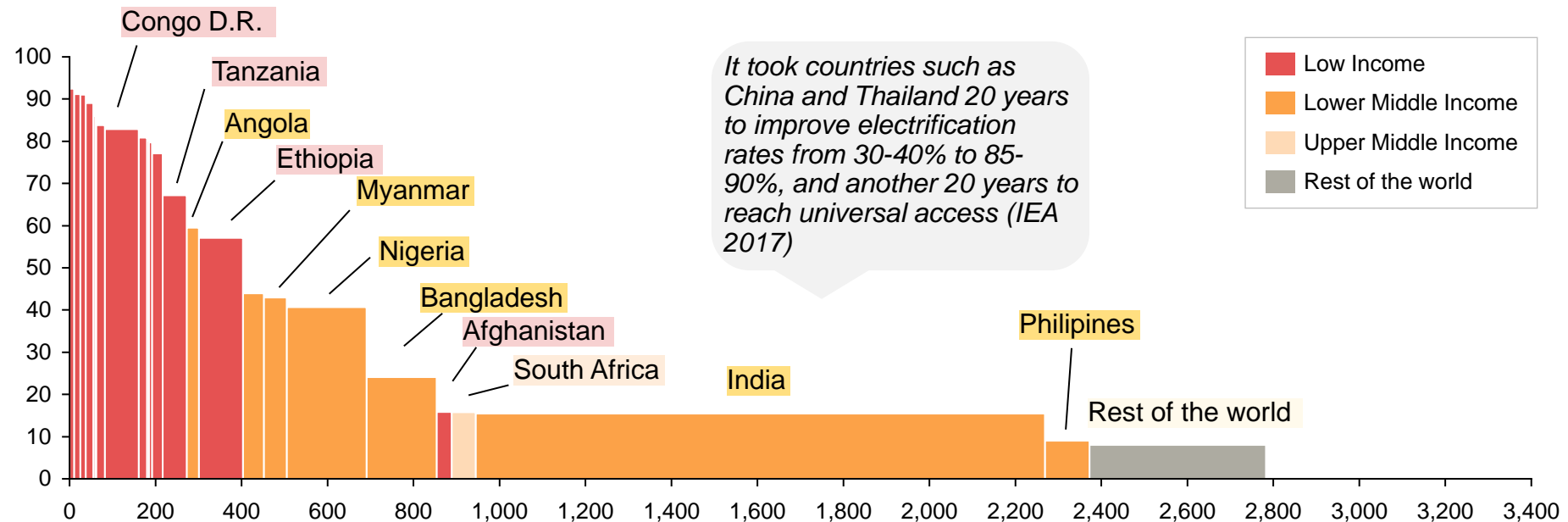

- Most of nearly 1.1 billion people without access to electricity live in under-developed economies of sub-Saharan Africa. Around 400 million people in this category live in low-income economies, whereas more than half a billion people are in lower-middle-income economies.
- Some African upper-middle-income countries, such as Angola and South Africa, have large numbers of people without electricity access. Half of the world population lives in upper-middle-income or high-income countries, and only a few dozen million people in these countries have no access to electricity.

In general, access to clean cooking varies with the average economic wealth of the country

Cumulative population lacking access to clean cooking per country economic wealth

% of people per county vs. total population of country; average national income (2017)

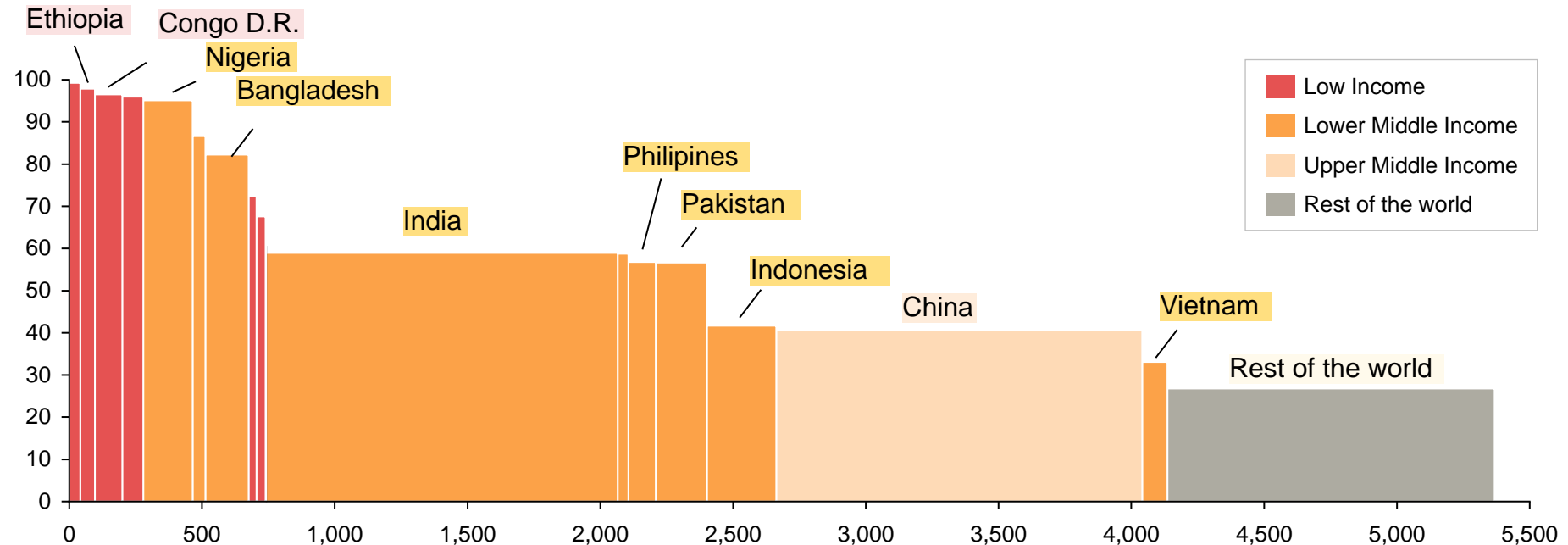

- 1.7 billion of the 2.8 billion people deprived of access to clean fuel for cooking live in lower-middle-income economies, mostly in developing Asia. Just four countries (India, Indonesia, Pakistan and Bangladesh) account for nearly 1.2 billion people without clean cooking fuels, almost seven times the population of Nigeria.
- Furthermore, 550 million people without access to clean fuel for cooking live in low-income economies which are almost completely consisted of sub-Saharan countries. More than 650 million people live in upper middle income economies (In China 570 million)

87% of total population without access to electricity are in rural areas

Urban *versus* rural distribution of people without access to electricity

Million, % (2016)

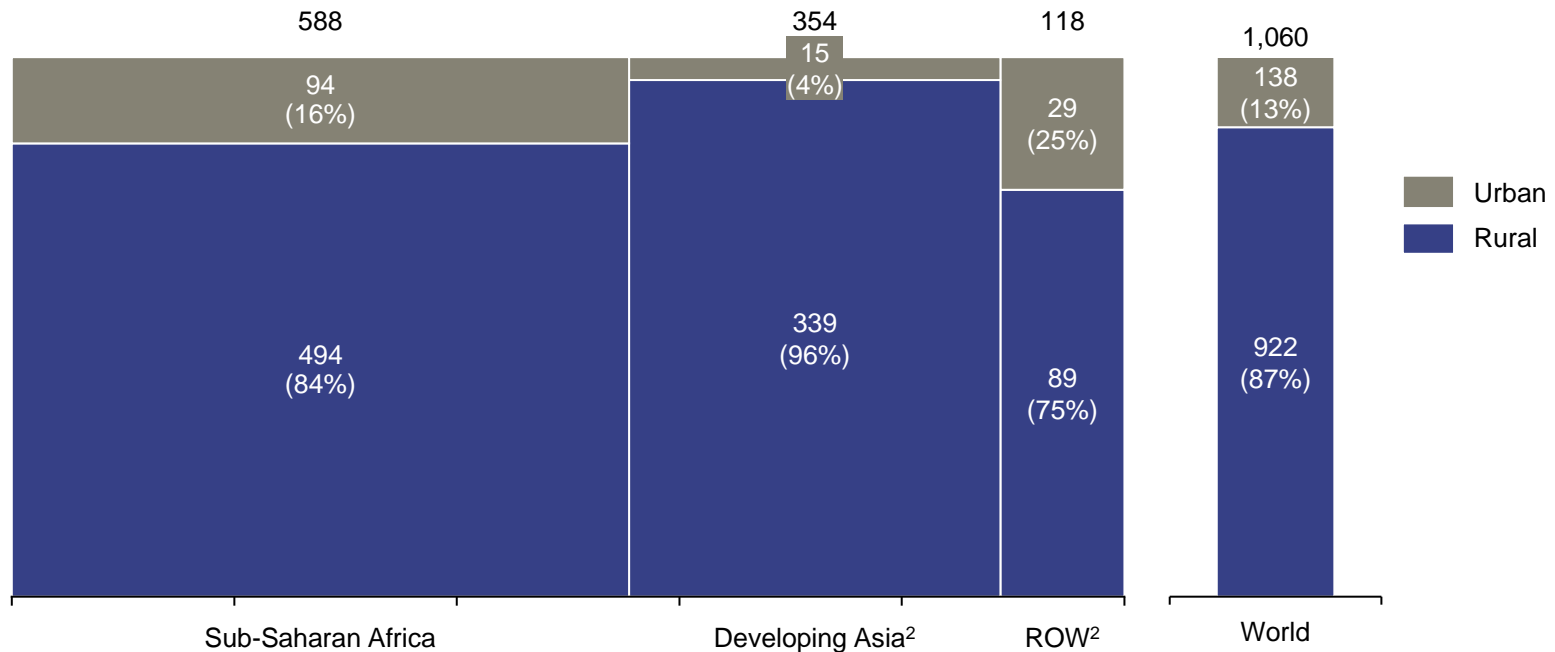

- **87 percent of the world population without access to electricity was living in rural areas** in 2016, which is more than six-times higher than the total affected population living in urban areas. In sub-Saharan Africa, just 23 percent of the rural population **has access to electricity**, compared with 81 percent in developing Asia.
- **4 percent of world's urban population still does not have access to the electricity.** In Sub-Saharan Africa, 71% of urban populations have been electrified, the lowest rate in the world. In India, 6.5 million people in urban areas still lack access to electricity, while, in Bangladesh, the figure amounts to slightly less than 4 million.

Note: (1) Developing Asia: Bangladesh, Brunei, Cambodia, China, India, Indonesia, Korea DPR, Malaysia, Mongolia, Myanmar, Nepal, Pakistan, Philippines, Singapore, Sri Lanka, Thailand, Viet Nam, Afghanistan, Laos and Pacific nations; 2 ROW: Rest of the world.

Source: World Bank online database on population (<http://data.worldbank.org/indicator/SP.URB.TOTL>); IEA WEO Energy Outlook 2017, A.T. Kearney Energy Transition Institute, Poverty 37

84% of total population without access to non-solid fuel are located in rural areas

Population without access to non-solid fuel in different regions

Million people, % (2016)

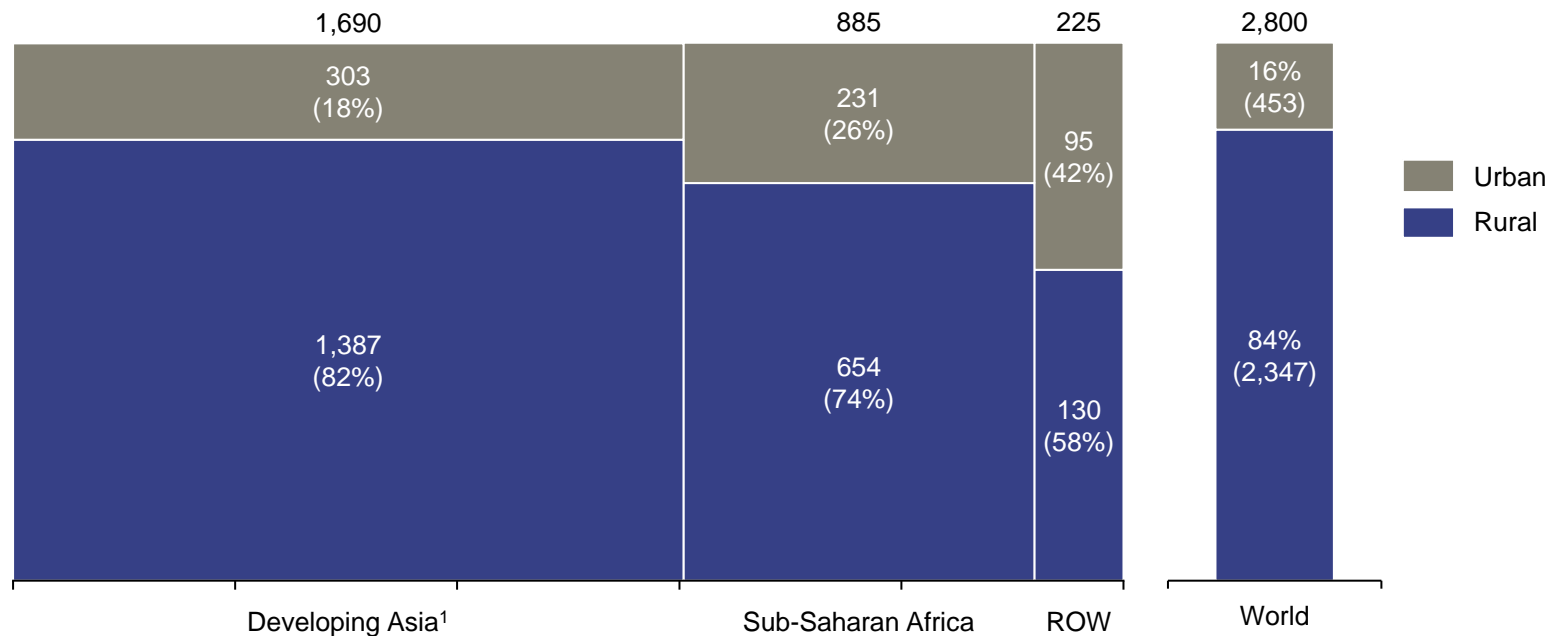

- Most of the population lacking access to non-solid fuel lives in rural areas. This is particularly true in developing Asia¹, where **more than eight of 10 people** lacking access to non-solid fuel live in rural areas.
- The two main regions lacking access to non-solid fuel are developing Asia (including India and China) and Sub-Saharan Africa. Together, they account for more than 90% of the total population lacking access to non-solid fuel.
- **Between 1990 and 2016**, the rate at which people gained access to non-solid fuel **was much higher in urban areas**, at 1.9%, than in rural areas, at 0.7% per annum.

Note: (1) Developing Asia: Bangladesh, Brunei, Cambodia, China, India, Indonesia, Korea DPR, Malaysia, Mongolia, Myanmar, Nepal, Pakistan, Philippines, Singapore, Sri Lanka, Thailand, Viet Nam, Afghanistan, Laos and Pacific nations

Source: World Bank online database on population (<http://data.worldbank.org/indicator/SP.URB.TOTL>)

If current policies and commitments are maintained, the global population without access to electricity should stagnate between 2020 and 2040

Prediction of global population¹ without access to electricity

Million people, 2016-2040

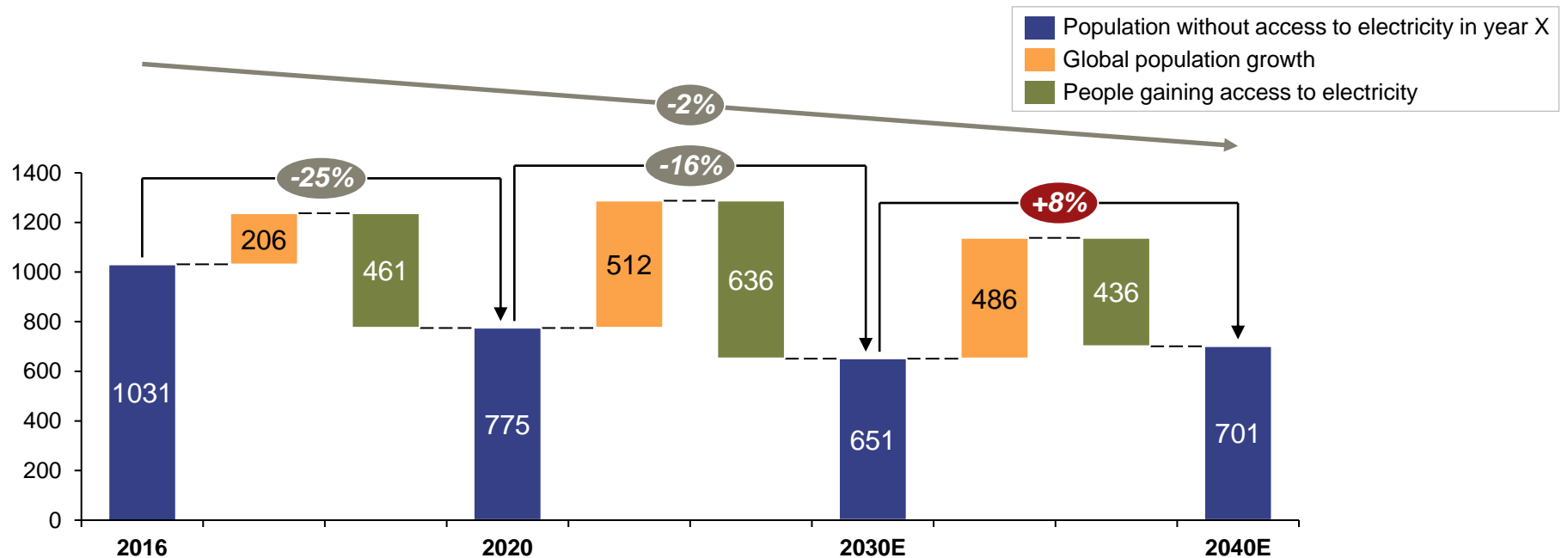

- From 2016 to 2030, the number of people without access to electricity should decline from 1,031 million to ~650 million.
- After 2030, the global population without access to the electricity should start growing again. Deprived population is expected to exceed 700 million people, an estimated 9% of the global population at that time. Nearly 95 percent of the deprived population will be in sub-Saharan Africa.

By 2040, 95% of the global population without access to electricity will be in sub-Saharan Africa

Prediction of regional populations without access to electricity

Million people, 2016-2040

India

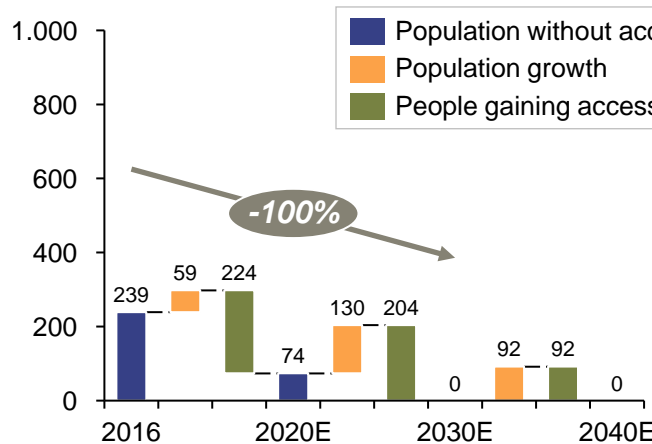

Developing Asia

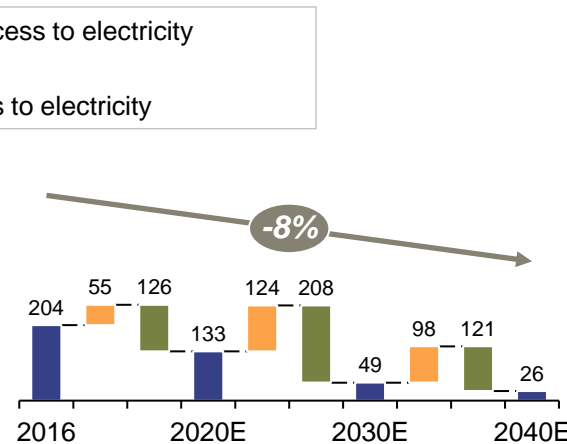

Sub-Saharan Africa

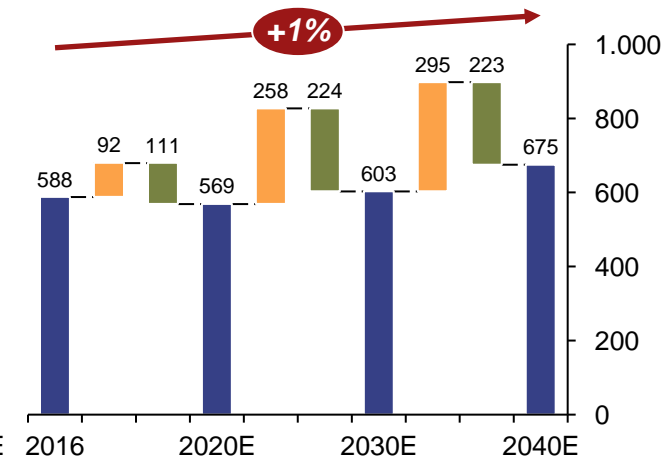

- **India is expected to achieve universal access** to electricity across its population by 2030, which would involve 430 million people being connected in the next 15 years.

- By 2040, it is expected that **25 million people will still lack access to electricity in other developing Asia countries**, mostly in Cambodia, Myanmar and Laos.

The pace of electrification in sub-Saharan Africa is expected to be rapid as well, **with more than 450 million people gaining access** to electricity by 2040. However, these achievements are likely to be offset by population growth in next 25 years.

- Urbanization plays key role in the electrification, with 98% of global population growth occurring in urban areas.

About 600 million people are expected to gain access to electricity by 2030, using a variety of energy sources and technical solutions

People gaining access to electricity by 2030, investment committed, expected technologies used

Million of people (*left*); US\$ billion (*right*) – IEA New Policy Scenario

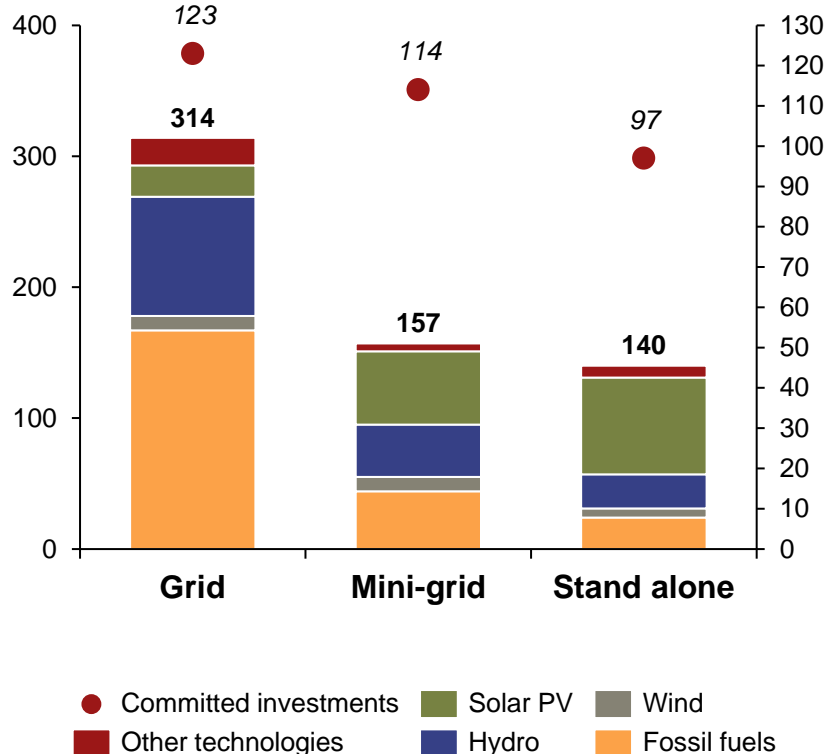

- **Funds of \$334 billions have been committed to provide access to electricity to ~610 million people by 2030**, through grid connections, mini-grid developments and stand-alone solutions deployment.
- Existing and planned policies will result in 44 million people per year gaining access to electricity between 2016 - 2030.
- **The number of people without access to electricity is projected to fall by ~35% by 2030**, despite an increase in the global population. However, this still means that 674 million people (8% of the world's population) are without access to electricity in 2030, 90% of which will be in rural areas.
- **Centralized power grids remain the primary means of electrification.** On average, they are cheaper (392 US\$/person) than mini-grids (726 US\$/person) and off-grid solutions (693 US\$/person).
- If grid-connection do not provide more flexible and sustainable technological solutions, mini-grid and stand-alone solutions might be preferred in cases where upfront investments to extend national grids cannot be financed or where development timescales are very long.

Providing universal electricity access would require additional investments of about \$393 billion

Additional investment required, possible technologies used to provide universal electricity access

Million of people (*left*); US\$ billion (*right*) – IEA Energy for All case

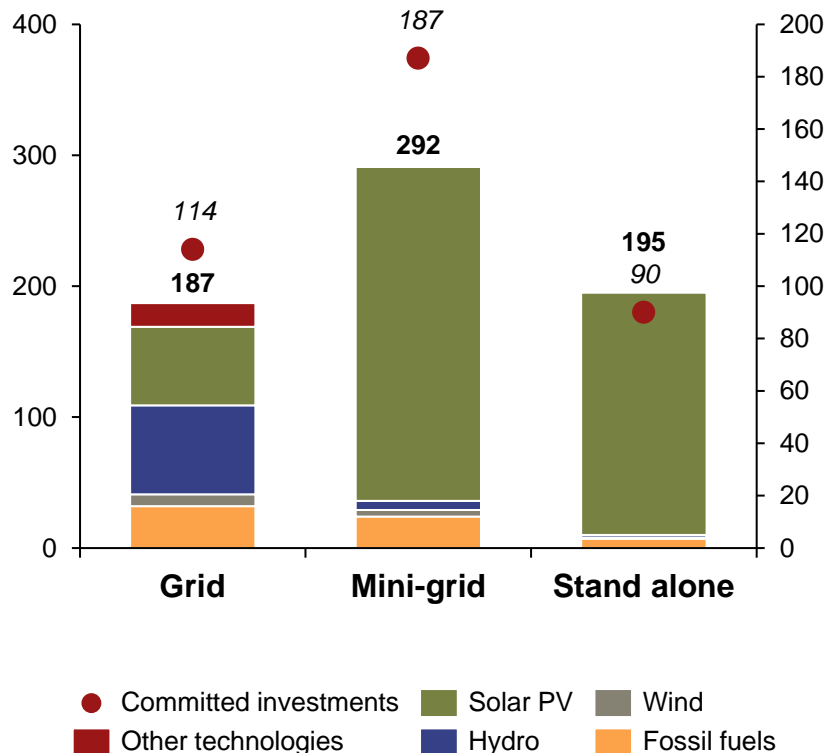

- **Additional investment of \$391 billion** would be required, on top of the \$334 billion already committed, to provide electricity to all (1,060 million people) by 2030. This implies a **total global investment of around \$725 billion**, an average of \$52 billion a year between 2016 and 2030—more than twice the amount involved in existing and planned policies.
- **Most of additional investments (61%) are to be provided to sub-Saharan Africa.** Rest of investments are equally shared mostly between India and rest of developing Asia.
- Over 485 million people gaining electricity access in IEA's Energy for All Scenario do so through **decentralized systems**—72 percent of the total number the scenario says will gain access to electricity. Of these, roughly 195 million gain access through **stand-alone solutions** (predominantly solar PV) and 290 million through mini-grids. But expanding grids continue to deliver incremental energy supply, providing 185 million people—the remaining 28 percent—with access to electricity.

The global population without access to non-solid fuels should decline, according to the IEA's New Policy Scenario

Evolution of the number of people without access to non-solid fuels

Million people

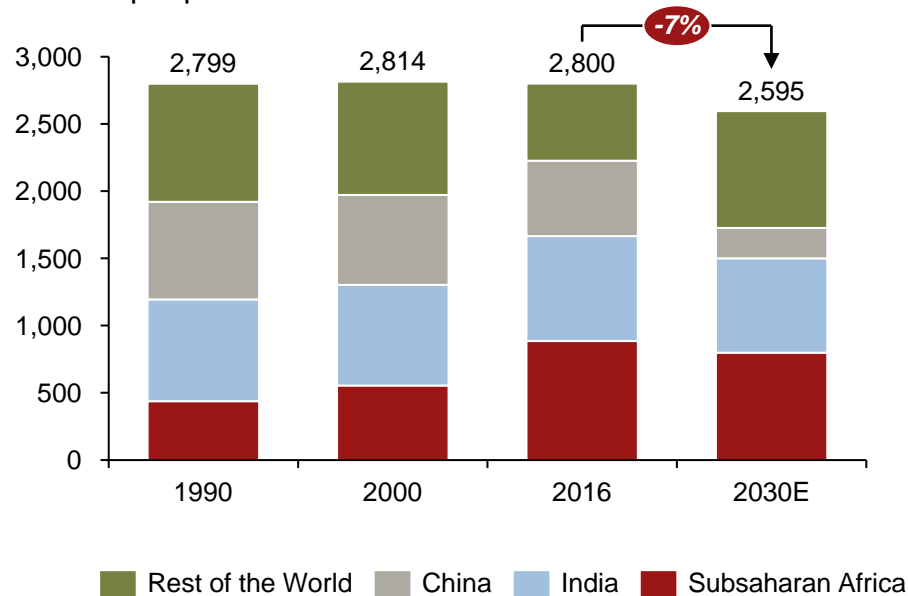

Evolution of the share of the population with non access to solid-fuel

% of the population

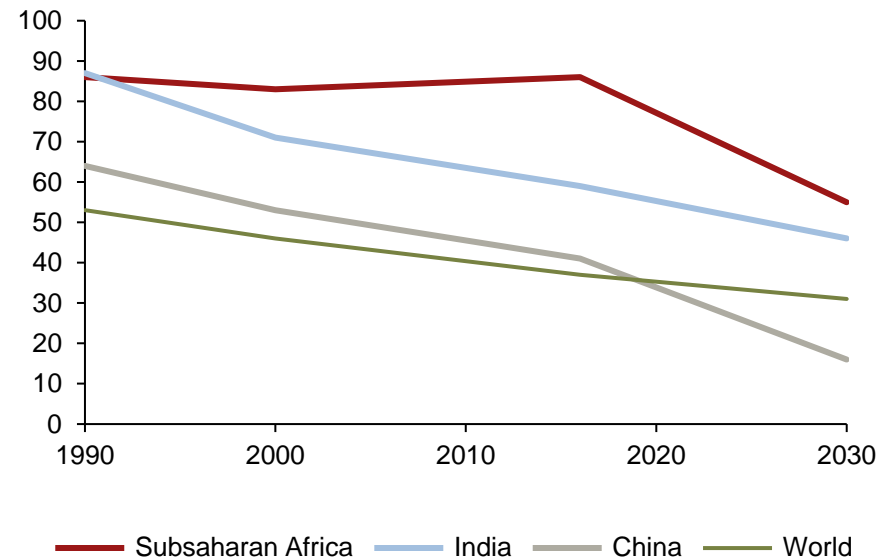

- The number of people without access to non-solid fuels will decrease by around 200 million between 2016 and 2030, falling below **2.5 billion people by 2030**, according to the IEA's New Policies Scenario. **Developing Asia** will record the largest number of affected people. In **India**, the number falls by 42 percent between 2016 and 2030, but, even so, **more than half a billion of people remain without access to electricity in 2030**. There is a downward trend in **China** too, but an estimated **145 million people** remain affected in 2030, 10 percent of the projected population in 2030. In **sub-Saharan Africa**, the number of people lacking access to electricity is expected to decrease by a modest 95 million between 2016 and 2030, falling to **700 million**.

Annual investment would need to triple to provide modern fuels to all by 2030

Average annual investment by technology

Billion dollars per year

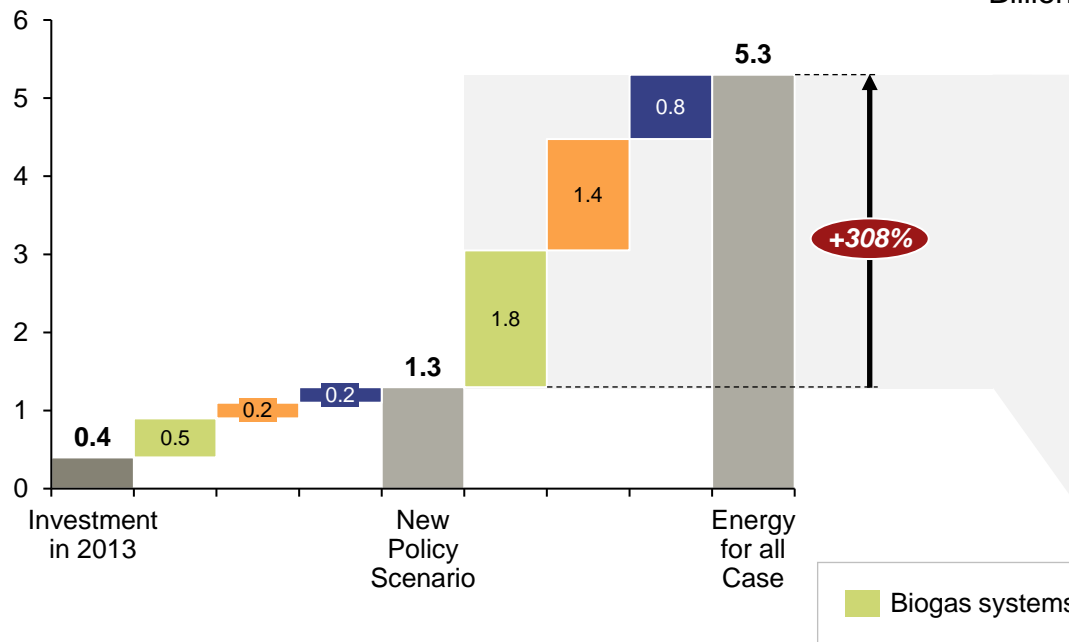

Estimated average annual additional investment by region, for energy for all

Billion dollars per year

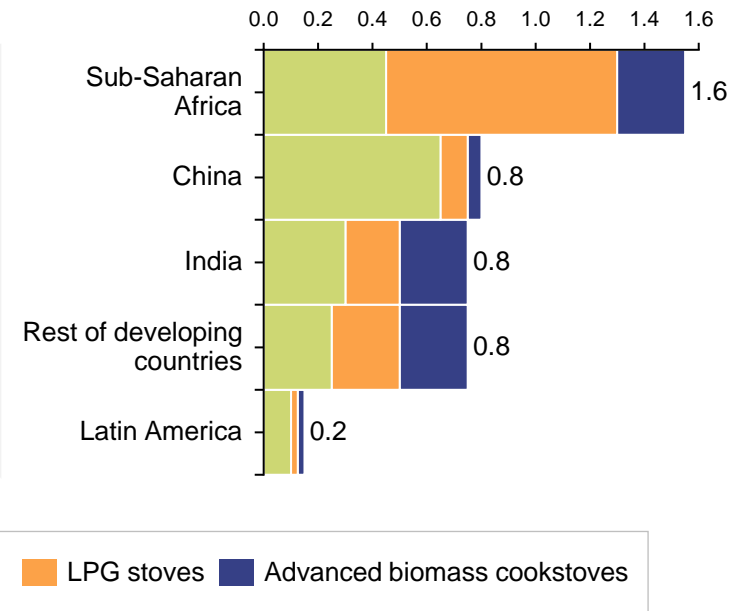

- According to the **IEA's Energy for All case**, additional investment of **\$74 billion** would be required to provide universal access to clean cooking facilities by 2030, about four times the level of investment in the New Policies Scenario. **Sub-Saharan Africa** would absorb **29% of the additional investment**, with nearly two-thirds going to countries in **developing Asia**. The additional investment includes **\$17 billion for advanced biomass cookstoves** for 250 million households. A further **\$37 billion** would be spent on **biogas systems** for another 70 million households. Spending of **\$20 billion on LPG stoves** would benefit another 240 million households. In rural areas, investment is weighted towards biogas systems and advanced biomass cookstoves; and in urban and peri-urban areas, LPG stoves are favored.

3. Technology solutions



Access to electricity can be provided by mixing almost all power sources and supply technologies

Main primary power sources

Main supply technologies

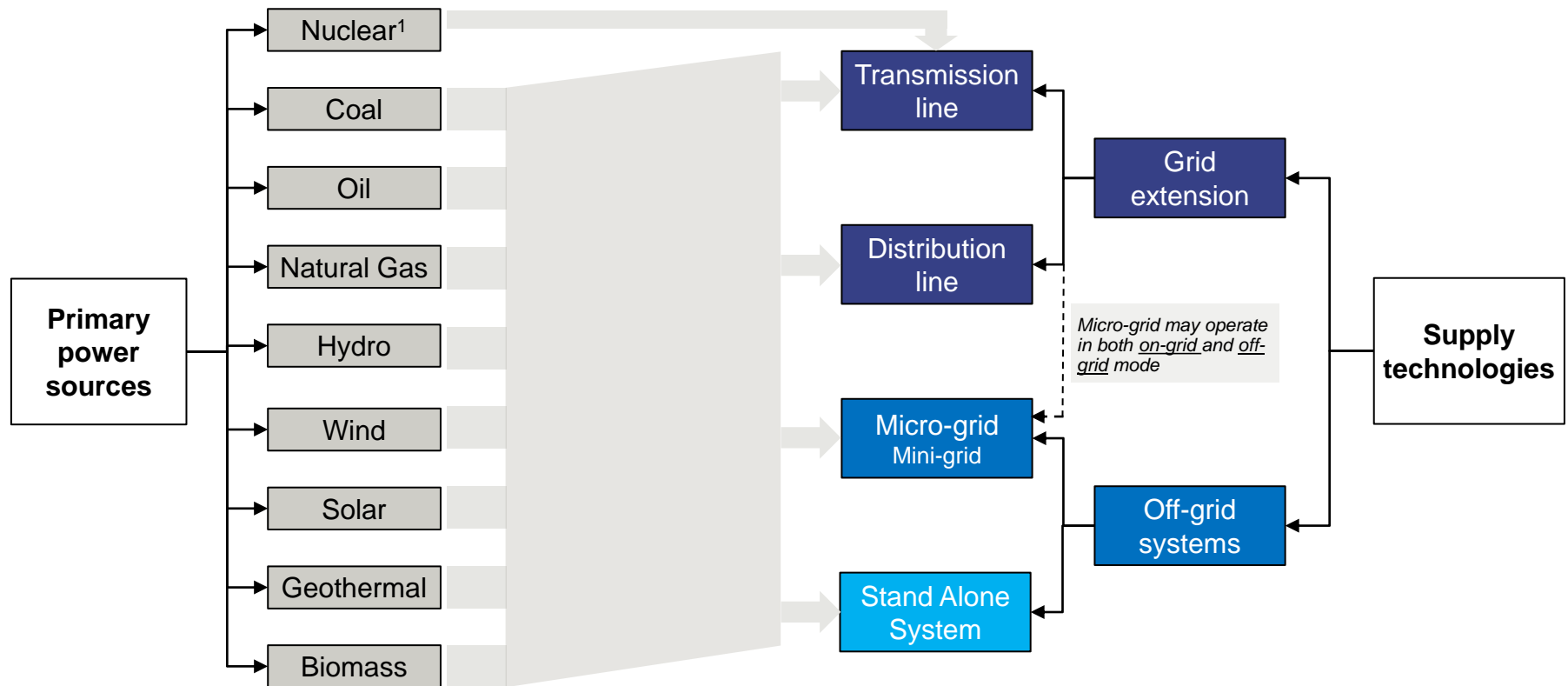

Global access to electricity has been accelerating over the past two decades, primarily because of increased supply from coal and hydropower

Annual number of people gaining electricity access by fuel type in developing countries

Million people, %, 2000-2012, 2012-2015

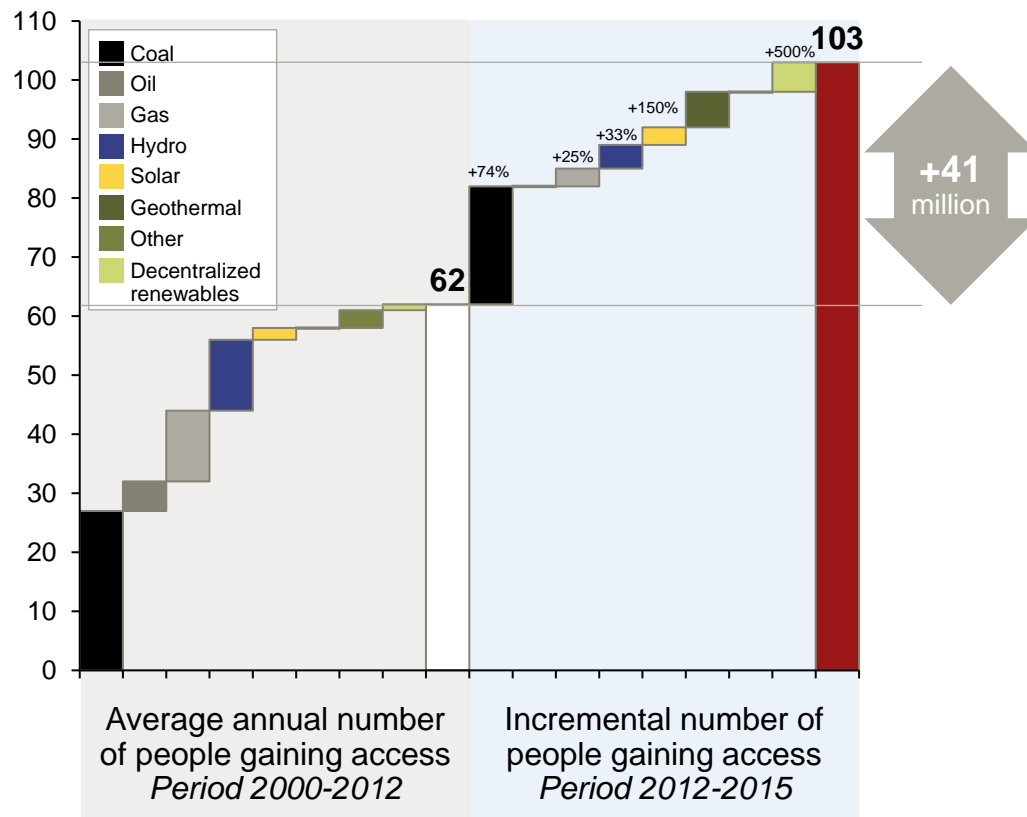

- Over the past two decades, the number of people gaining electricity access each year has been accelerating, rising from 62 million, between 2000 and 2012, to 103 million, in the 2012-2015 period.
- Of the 1.2 billion people who have gained access since 2000, nearly 97% gained access through grid extensions.
- From 2000 to 2012, 72% percent of people have gained access to electricity with power generated from fossil fuels (45% coal, 19% natural gas and 8% oil).
- From 2012 to 2015, grid level renewables (mainly geothermal, hydro and solar) have accounted for about one-third of new connections. Meanwhile, the development of decentralized renewables has been accelerating, accounting for 12% of new electricity connections.
- The declining costs of renewables and efficient end-user appliances, along with innovative business models for financing electricity access, have helped transform energy access, especially in rural areas.

A wide range of technologies at various scale exists

Most widely used electricity (or lighting¹) supply technologies

“While kerosene lamps provide only 1% of global lighting, they are responsible for 20% of lighting-related CO₂ emission and consume 3% of the world’s oil supply, while a compact fluorescent light (CFL) or LED light is 1000 times more efficient.” IPCC (2014)

Stand-alone (<1kW, or one household)	Mini-grid (<1MW, or one town)	Grid (centralized / utility scale)	Power source
<ul style="list-style-type: none"> • Candle¹ • Kerosene lamp¹ 	<ul style="list-style-type: none"> • Diesel generator 	<ul style="list-style-type: none"> • Thermal fossil power plant (coal, gas, oil, nuclear) 	Fossil fuel
<ul style="list-style-type: none"> • Pico solar (<10W) • Solar home system • Pay-as-you-go (PAYG) solar 	<ul style="list-style-type: none"> • PV plant • Hybrid diesel generators/PV 	<ul style="list-style-type: none"> • PV plant • CSP plant 	Solar
	<ul style="list-style-type: none"> • Pico/micro hydropower 	<ul style="list-style-type: none"> • Hydropower plant 	Hydro
<ul style="list-style-type: none"> • Micro wind mill 	<ul style="list-style-type: none"> • Wind mill 	<ul style="list-style-type: none"> • Wind farm 	Wind
<ul style="list-style-type: none"> • Traditional fire¹ 	<ul style="list-style-type: none"> • Biomass power plants • Biogas power plant for electricity generation 		Biomass
<ul style="list-style-type: none"> • Gravity light¹ 	<ul style="list-style-type: none"> • ... 		Human powered
<ul style="list-style-type: none"> • Battery powered lamps & household appliances 	<ul style="list-style-type: none"> • Stationary battery storage 		Battery









On top of 1.1 billion people without electricity access, 1 billion people are connected but suffer from unreliable service levels, often backed up by diesel generators

Note: (1) Lighting only technologies. PV: Photovoltaic; (2) CPV: Concentrating Photovoltaic; (3) CSP: Concentrated Solar Power; Source: Bhattacharyya (2014), “Mini-Grids for Rural Electrification of Developing Countries, Analysis and case study from South Asia”; IEA (2017), WEO Energy Access Outlook.

Solar PV offers scalable applications with varying location, grid connection or power capacity requirements

Solar PV technology classification and applications

	Off grid			Grid connected		
	Pico PV	Non-domestic	Domestic	Residential/SHS ²	Commercial	Utility-scale
						
Size	Only a few watts	Varying sizes	Up to 5 kW	Up to 20 kW	From 0.2 to 5 MW	Up to 2GW
Application	Lighting, phone, radio or small appliances ¹	Wide range of applications	Households and villages not connected to the electricity network	Individual buildings/houses or electricity network	Buildings and electricity network	Electricity network
# of modern home powered	<i>not applicable</i>	<i>not applicable</i>	<i>not applicable</i>	Up to 20	Up to 5000	Up to 2 millions
LCOE range (US\$/kWh)		Highly variable		From 0.25 to 0.1		From 0.31 to 0.07

PROs

- Highly scalable solution
- Few geographical condition constraints
- Low operating costs
- Producing no noise
- Visually unobtrusive

CONs







- Intermittent energy
- Solar panel reliability
- Maintenance in dusty areas (note: significant improvements in some regions in managing this issue)
- Asynchronous nature of solar PV generation may be problematic for power systems

Note: (1) Such as telecommunication, water pumping, vaccine refrigeration and navigational aids; (2) Solar Home Systems

Source: IEA (2014), "Technology Road Map Solar Photovoltaic Energy"; IEA PVPS (2014), "Trends 2014 in Photovoltaics Applications"; IRENA, "Renewable Power Generation Costs in 2017"; A.T. Kearney Energy Transition Institute, "Solar PV FactBook"

Wind Power is a scalable technology, with different applications and power capacity requirements

Wind Power technology classification and applications

	Off grid			Grid connected		
	Micro Wind	HAWT ¹ Small	VAWT ² Small	Medium	Large Onshore	Large Offshore
						
Size	Up to 10kW	10kW to 100kW	10kW to 100kW	100kW to 1MW	Up to 20 GW ³	Up to 1.2 GW ⁴
Application	Wide range from lighting, phone, radio, small appliances...	Isolated households and villages		Utility scale connected to the power grid		
# of modern home powered	0 to 5	5 to 50	5 to 50	Up to 500	Up to 10 million	Up to 5 million
LCOE range (US\$/kWh)	Highly variable depending on technologies			From 0.04 to 0.012		From 0.09 to 0.02

PROs

- Sustainability (in on-shore areas)
- Lowest cost (onshore utility scale)
- Lifespan

CONs







- Intermittent energy
- Usually high quality wind sites are located in remote locations leading to higher investment in transmission infrastructure
- Social acceptance (e.g. noise, aesthetic pollution)
- Land footprint

Note: 1. HAWT – Horizontal Axis Wind Turbine; 2. VAWT – Vertical Axis Wind Turbine; 3. Capacity planned for Gansu Wind Farm in 2020 (China); 4. Capacity planned for Hornsea Project One in 2020 (North Sea)

Source: IRENA (Renewable power generation costs in 2017); A.T. Kearney Energy Transition Institute

Hydro Power offers scalable solutions, with different applications and power capacity requirements

Hydro Power technology classification and applications

	Off grid			Grid connected		
	Pico-Hydro	Micro-Hydro	Mini-Hydro	Small-Hydro	Medium-Hydro	Large-Hydro
						
Capacity¹	Up to 5kW	5kW to 100kW	100kW to 1MW	1MW to 10MW	10MW to 100MW	Up to 22.5 GW
Application	From lighting, phone, radio or small appliances to a wide range of applications		Households and villages not connected to the electricity network		Buildings and electricity network	
# of modern home powered	0 to 5	5 to 100	100 to 1,000	Up to 10,000	Up to 100,000	Up to 25 million
LCOE range² (US\$/kWh)	Highly variable, commonly find above 0.03			From 0.027 to 0.02		From 0.06 to 0.018

PROs

- Long lifespan (up to +100 years for small-large plants)
- Low operating and maintenance costs, low LCOE
- Short time to changes in load demand (within sec)
- Controllable power output (non-intermittent)

CONs

- High upfront investment costs
- Environmental footprint
- Highly depend on location and local conditions
- Sensitivity to droughts
- Impact on fish population

Electrification can follow various and progressive paths, from small local solutions, to mini-grids interconnections, up to national grid development

Framework for development of electricity system in a country with no universal access

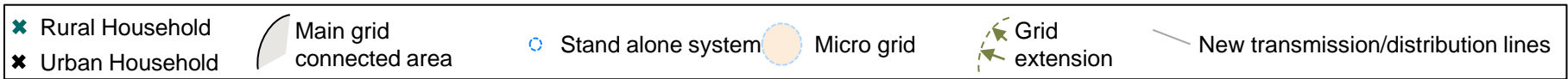

Urban electrification



Towards full electrification

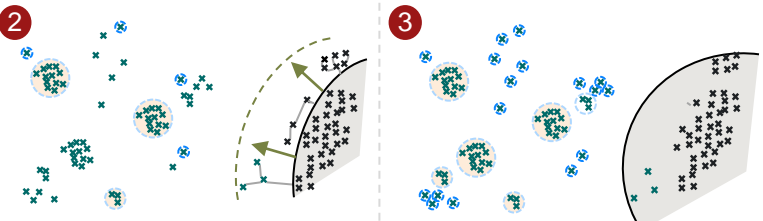

Towards full integration

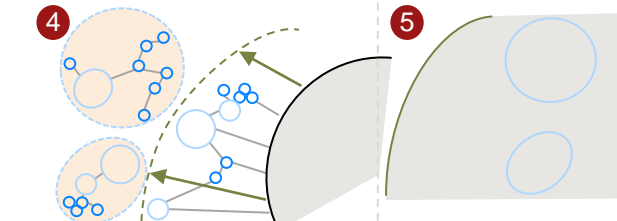

Individual systems

Battery powered lamps & household appliances; Pico solar (<10W); Micro wind mill; Gravity light...

- Urban area partially connected
- Rural areas without electricity access

Stand alone systems

Autonomous small power generation units for global household applications

- Isolated households equipped with standalone power systems
- Rural villages serviced by distributed power plants and connected via micro grids separated from the national grid
- Progressive extension of the main grid to nearby households
- Rural area fully equipped with decentralized electricity access
- Main grid system extended to maximum economic limit
- Electricity access to all guaranteed in the shortest-possible timeframe

(Mini) Grids systems

Connection of several power sources and loads through a grid

- With economic development, connection of households to nearby micro-grids, and extension of main grid to all micro-grids
- Country-wide synchronous grid with potential islanding of previous micro-grid systems for improved system robustness

Choices of on-grid or off-grid solutions rely on several criteria

Decision tree: on-grid vs. off-grid

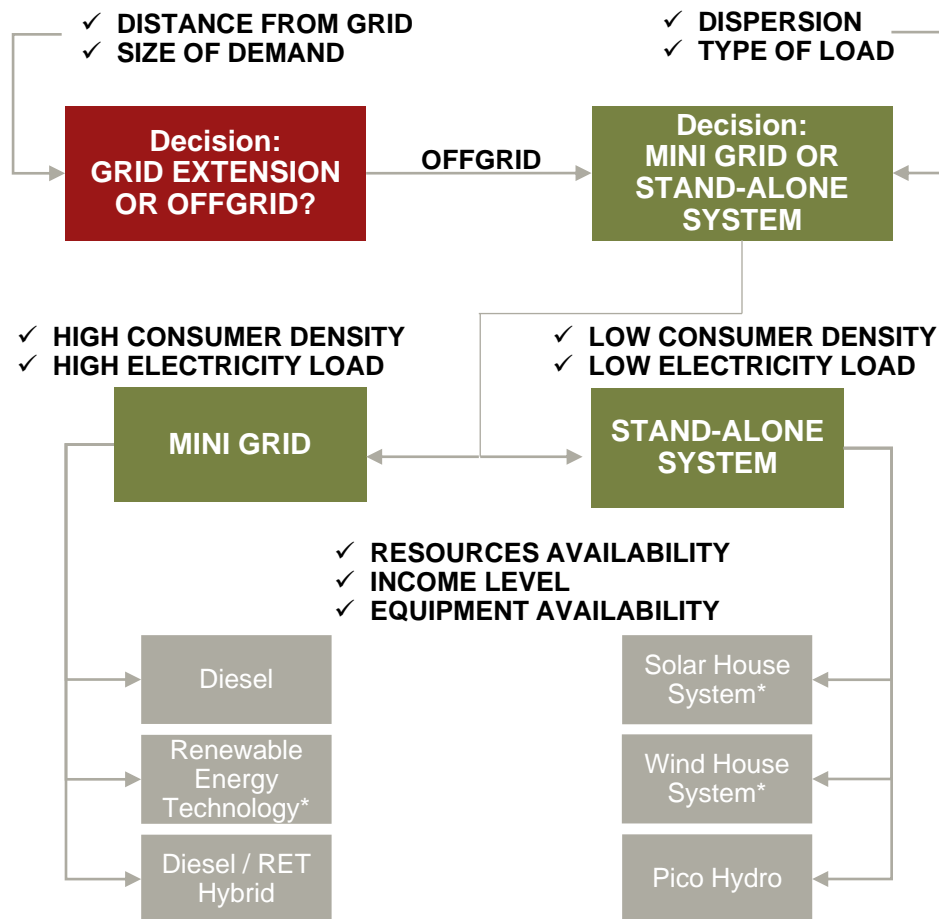

Key factors in decision-making on grid extension vs. off grid:

- **Financing:** upfront investment costs, affordability
- **Project economics:**
 - Infrastructure costs: distance to the national / centralized grid (incl. capacity of grid); field conditions...
 - Market size: population density and number of households, number and (expected) demand (growth) of productive end uses / industrial users; long-term demand (in kwh and terms of energy services) and peak load (in kw)
 - Energy costs: levelized costs of energy production of centralized solutions / decentralized options
- **Sustainability** and environmental footprint of solutions
- **Social acceptance:** the selection of socially and environmentally appropriate solutions

Fact card #1: Grid (extension)

Grid extension definition and illustration

Summary

A grid extension is the development of the actual grid through creation of new transmission and/or distribution lines

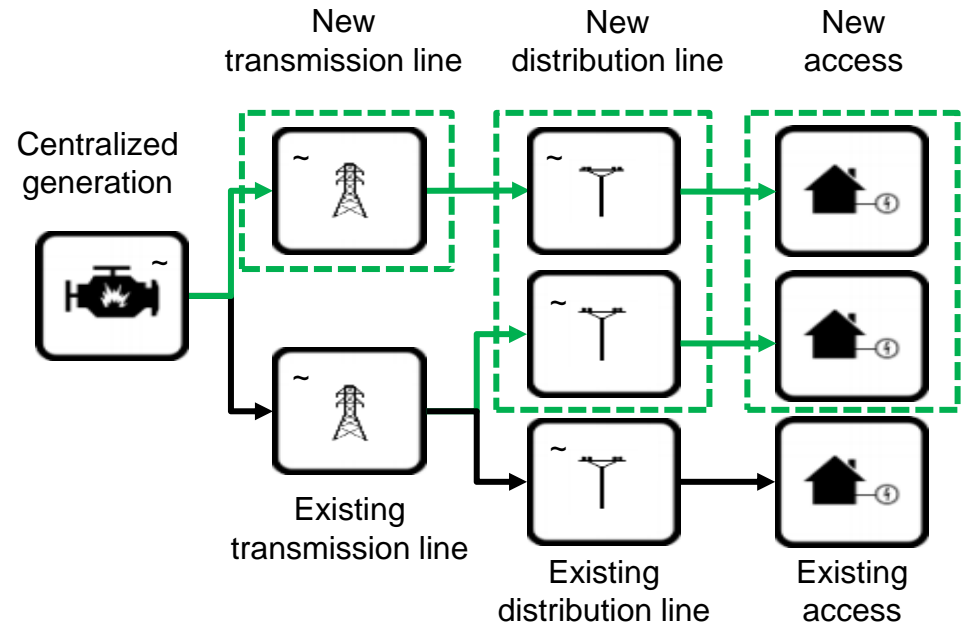

PROs

- Utility scale / connected solutions generally provide low LCOE range (see slides 48-50)
- High system flexibility, reliability and sustainability; enables industrial developments
- Well-fitted to set up incentive mechanisms, specific tariffs and support policies to populations
- Size / Portfolio effect: shared operations & maintenance; joint investments; scalable, adaptable and evolutive technology solutions;

CONs

- High upfront capital investment
- Long project development time before providing access to electricity, heavy contracting administrative tasks
- Dependence on fossil fuel imports and high GHG emissions from power plants
- Legacy of outdated infrastructure (standards)

Fact card #2: Mini grid

Mini grid definition and illustration

Summary

A mini grid is small distributed autonomous grid, usually covering 30-50km radius at low voltage with 5-10 MW power stations.

Since both mini grid and stand-alone system are off grid system, electricity production should cover the demand at any time. In case of insufficient power production or potential, it is required to introduce load management and deploy backup solutions. Adequate forecasting is equally or even more important than in grid system

PROs

- High quality and reliable supply
- Supply also available for non-domestic demand
- Could generate local income
- Renewables helps mitigate GHG emissions and are independent of fossil fuel price fluctuations
- Well-designed, *hybrid* system maximizes effectiveness and efficiency.

Example: Renewable power generators, such as wind turbines and solar photovoltaic, diesel generators and a storage unit deliver electricity to a small-medium size isolated community

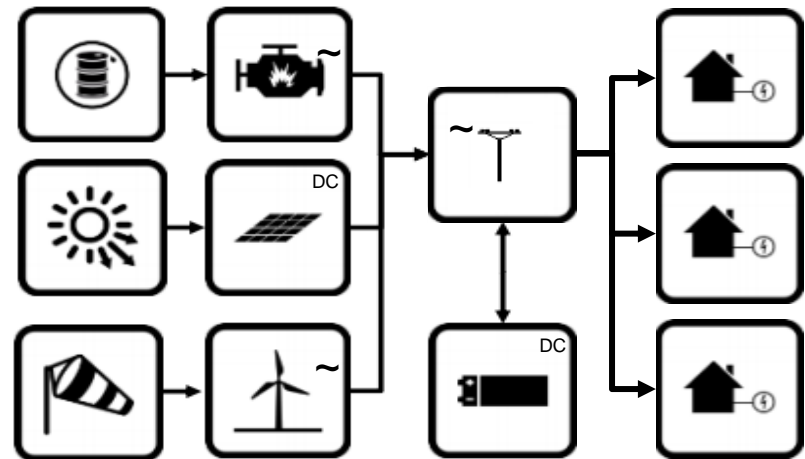

CONs

- Upfront capital investments
- Availability and cost of decentralized / local management
- Often limited scope of applications
- Sensitivity to intermittent renewable sources to be counterbalanced by electricity storage solutions

Fact card #3: Stand-alone system

Stand-alone system definition and illustration

Summary

A stand-alone system is an off-the-grid electricity system for locations that are not fitted with an electricity distribution system.

Since both mini grid and stand-alone system are off grid system, electricity production should cover the demand at any time. In case of insufficient power production or potential, it is required to introduce load management and deploy backup solutions. Adequate forecasting is equally or even more important than in grid system

PROs

- Lower upfront capital investment
- Sizeable individual solutions
- Generally provide a services (light, radio, heating...) in addition to power
- Immediate access to electricity / electricity services

Example 1: Solar home system (SHS), stand alone solar PV system with storage

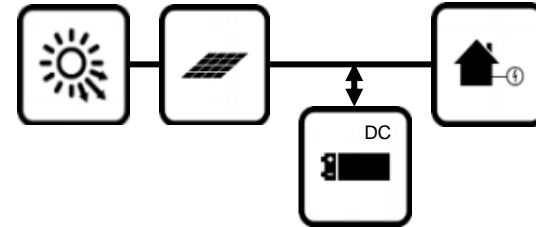

Example 2: Hybrid wind-diesel stand alone system with storage

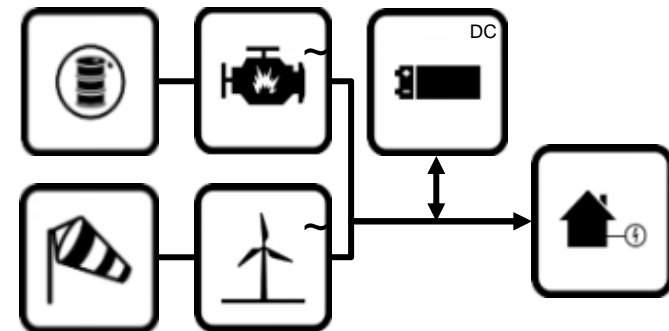

CONs

- Higher LCOE
- Sustainability compared to more robust solutions
- Limited range of application of some individual solutions
- More impacted by intermittency of power sources, lower reliability of the system
- Often requires user expertise

Fact card #4: Mini/Micro grid, step-by-step process to develop distributed energy systems, applicable for rural electrification

Project developer guidelines to implement a decentralized energy systems

Illustrative

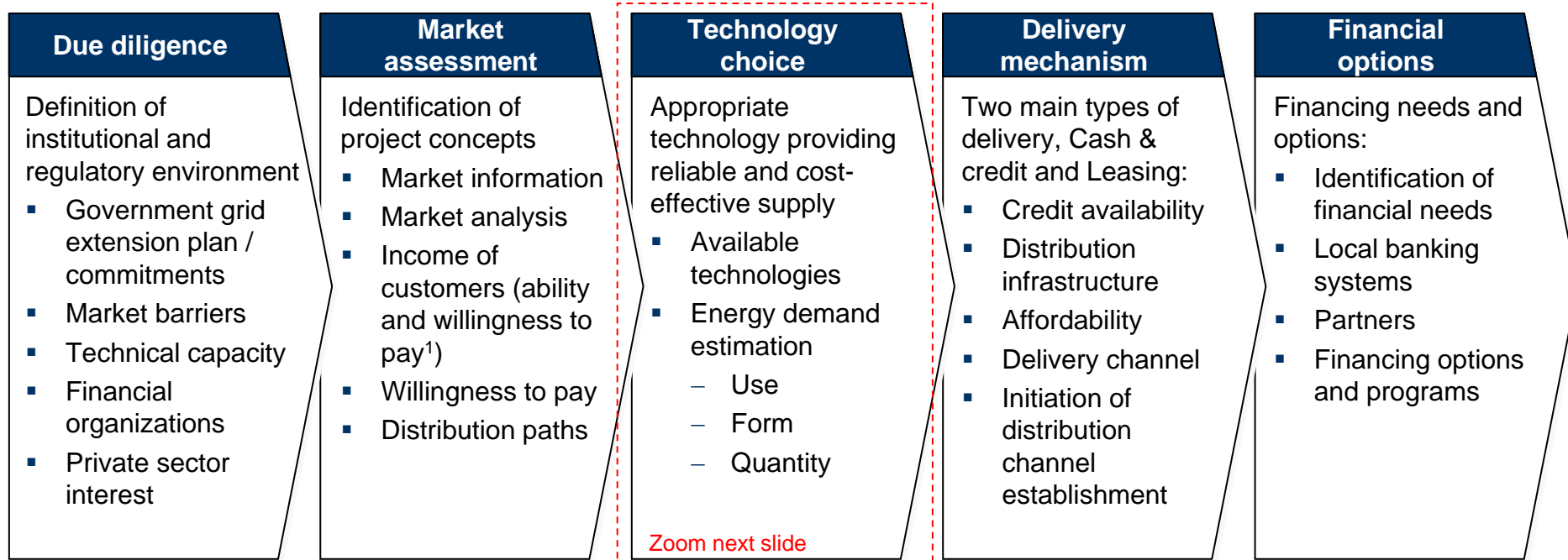

Note: (1) Situations have risen where villagers were not willing to pay higher mini-grid tariffs than their countrymen served by grid extension. Source: ESMAP (2001), "Best practice manual: promoting decentralized electrification investment.. World bank"; Bhattacharyya (2014), "Mini-Grids for Rural Electrification of Developing Countries, Analysis and case study from South Asia"

Fact card #5: Mini/Micro grid plan for rural electrification

Overview of technical solutions and decision for rural mini-grid development

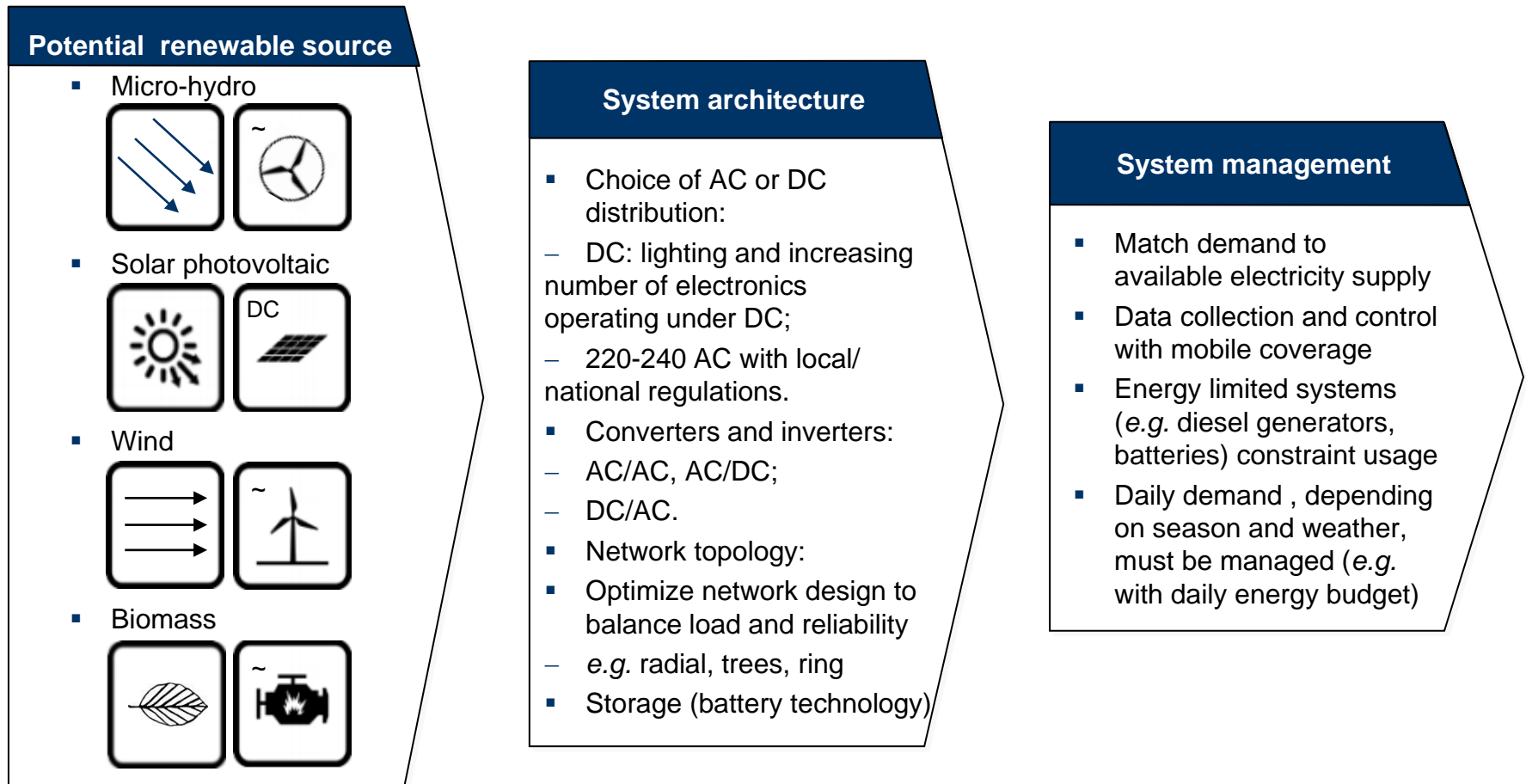

Note: Pictures adapted from Blechinger (2013)

Source: Bhattacharyya (2014), "Mini-Grids for Rural Electrification of Developing Countries, Analysis and case study from South Asia"; Blechinger (2013), GIZ Mini-grid workshop, "Hybrid Mini-Grids: A Huge Market for Rural Electrification and Island Energy Supply"

The economic choice between the grid extension and the mini grid option depends on the distance of the electrification area from the grid

Theoretical economics: grid-extension vs. mini-grid

US\$, kilometer

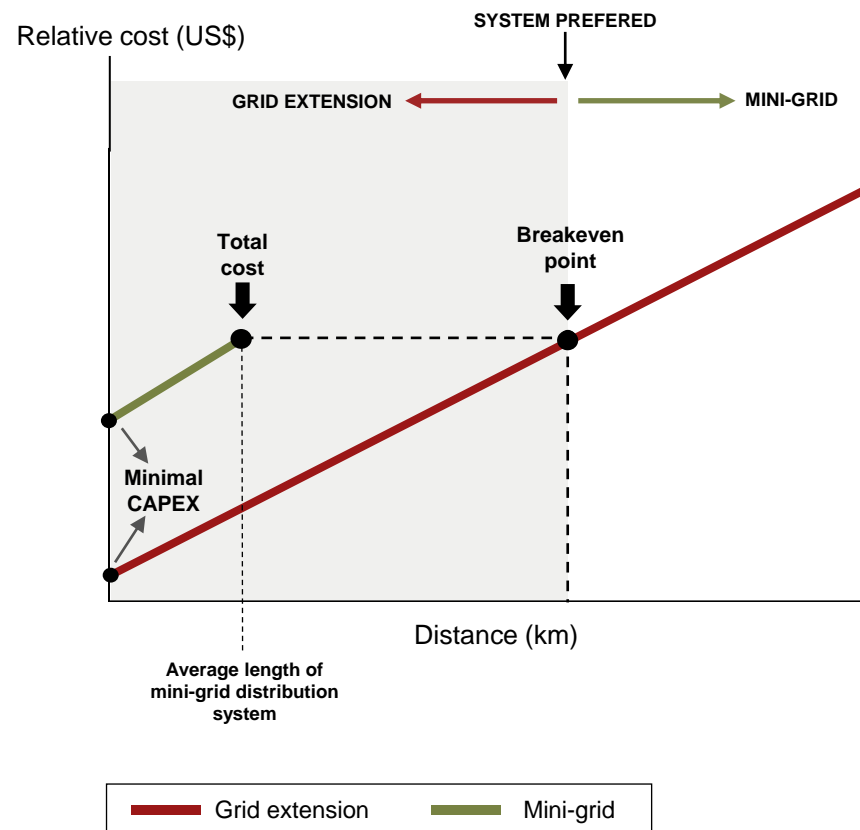

- Capex is generally higher in mini-grid power systems, while the cost of adding distribution infrastructure is similar in mini-grids and grid extensions. The relative total cost of off-grid systems can be estimated by including the average length of distribution lines in (typically 10-15 km) in the calculation.
- Furthermore, since Capex in mini-grid systems is normally a few times higher, investing the same amount in grid extensions should result in the addition of distribution lines of greater length overall. **The break-even point is the point at which grid extension becomes uneconomic for previously mentioned reasons.**
- **The costs of on-grid and off-grid power systems depend on local conditions.** Variations in cost reflect the approaches electric utilities have taken in design, equipment of lines and hardware procurement.
- Since the affected population usually has limited financial resources, capital costs are a principal component of the life-cycle cost of line construction. The cost of labour and materials for three-phase line construction typically ranges **from \$8,000 to \$10,000 per kilometer**, with the costs of materials alone averaging \$7,000 per kilometer (note that these figures are highly country-specific).
- There are various potential options for reducing the cost of grid extension, including: using single-phase construction, using higher voltages, considering the life-cycle costs of transformers rather than only their initial capital costs, and standardizing materials and designs, among others.

On average, countries would need to use less than 0.1 percent of their land for solar PV to reach 1,000kWh per person per year

Additional solar PV installed capacity required to reach 1,000kWh/y per capita⁽¹⁾
GW, Sub-Saharan Africa & South Asia

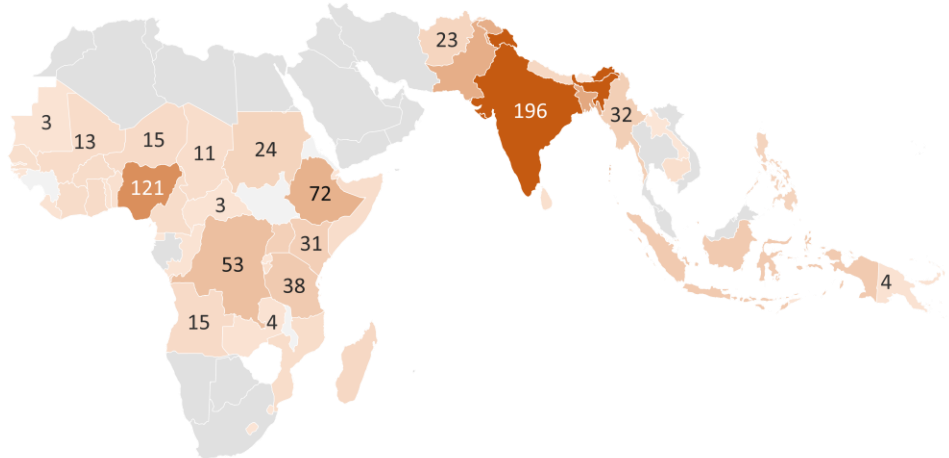

Fraction of total area per country
‰, Sub-Saharan Africa & South Asia

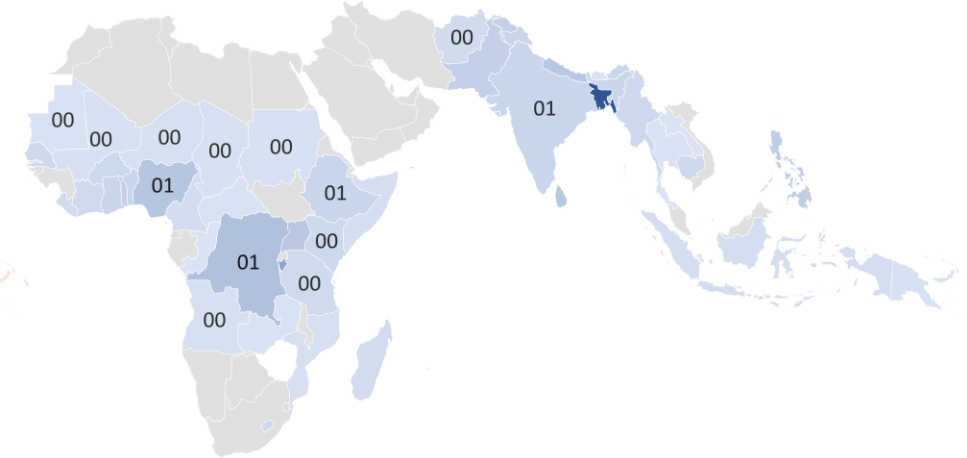

- Electricity generation in 2017 amounted to 25,570 TWh. This would need to increase by 1,420 TWh to solve energy poverty in sub-Saharan Africa and developing Asia, equivalent to around 5% of total electricity generation in 2017.
- Sub-Saharan Africa and South and Southeast Asia would need to add a combined 1,080 GW of solar PV capacity to meet increased electricity demand.
- Installing nearly 570 GW of solar capacity in sub-Saharan Africa would require 5,800 km² of land—just 0.045% of total area of the region. Developing Asia requires slightly less additional capacity—510 GW—which would cover 0.07% of the region's total area. In 2017, 2.4 GW of solar PV capacity was installed in sub-Saharan Africa, equivalent to around 2% of total installed power-generation capacity in the region.

On average, countries would need to use less than 0.9 percent of their land for wind power to reach 1,000kWh per person per year

Additional wind power installed capacity required to reach 1,000kWh/y per capita⁽¹⁾
GW, Sub-Saharan Africa & South Asia

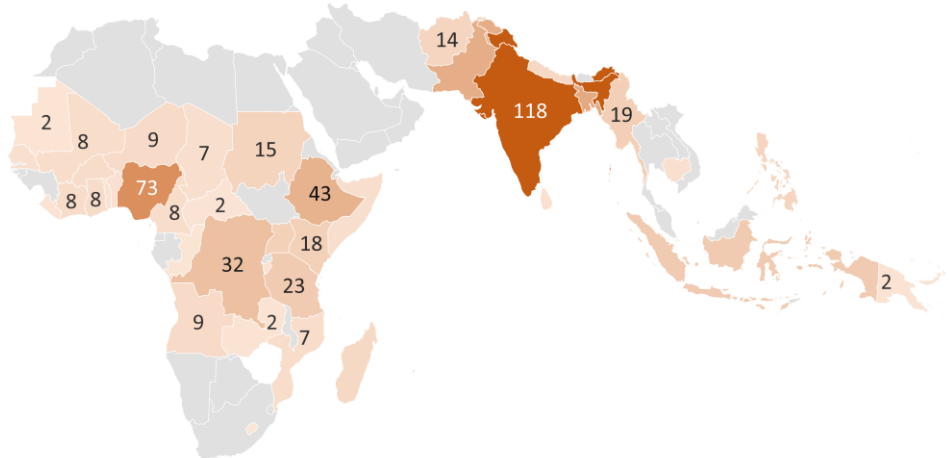

Fraction of total area per country
‰, Sub-Saharan Africa & South Asia

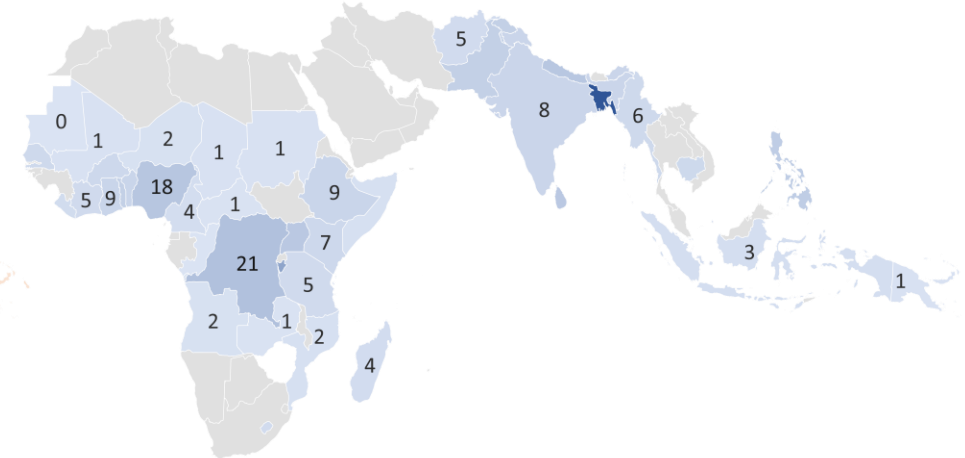

- Electricity generation in 2017 amounted to 25,570 TWh. This would need to increase by 1,420 TWh to solve energy poverty in sub-Saharan Africa and developing Asia, equivalent to around 5% of total electricity generation in 2017 and 22% of total renewable-energy production in 2017.
- Sub-Saharan Africa and South and Southeast Asia would need to add a combined 650 GW of wind-generation capacity to meet increased electricity demand.
- Installing nearly 340 GW of wind capacity in sub-Saharan Africa would require 0.68 percent of the region's total land. Developing Asia requires slightly less additional capacity—310 GW—which would cover 1.2% of the region's total area.

The remaining capacity of small hydro could contribute on average only 26% of the energy required to bring the population above 1000kWh/y/p

Estimated remaining power capacity from small hydropower

GW, Sub-Saharan Africa & South Asia

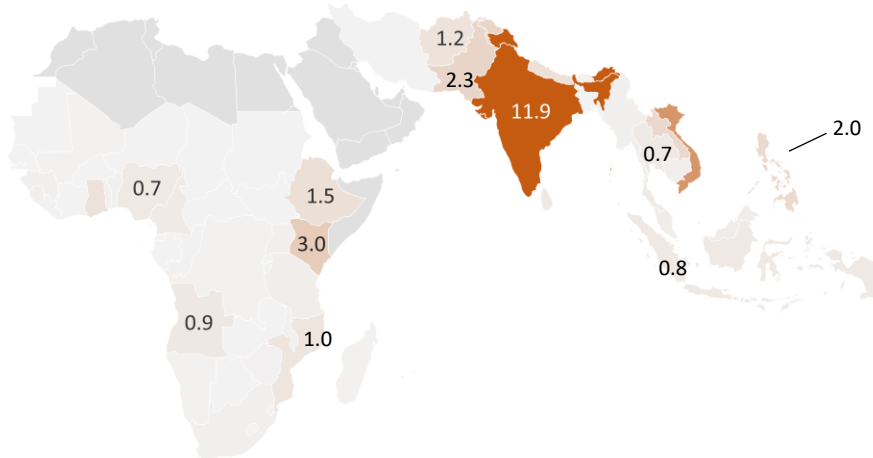

Potential contribution of small hydropower to reach 1000kWh/y/p

% of energy required, Sub-Saharan Africa & South Asia

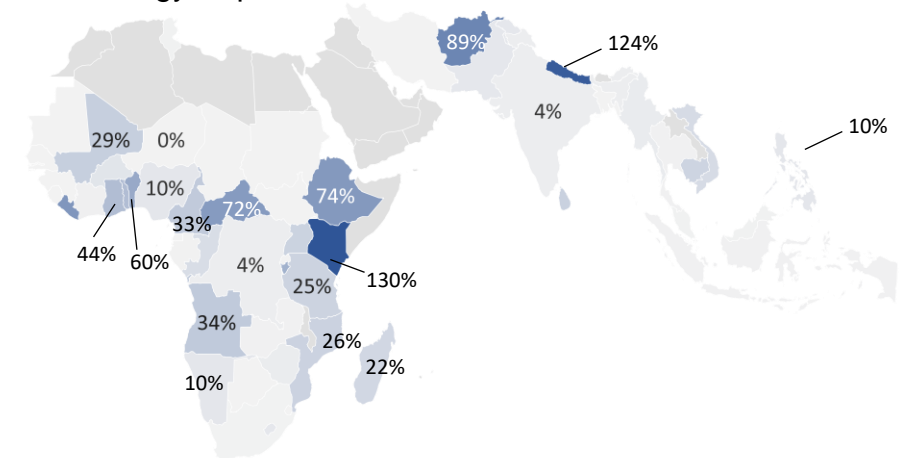

- Electricity generation in 2017 was 25,570 TWh. In order to solve energy poverty in sub-Saharan Africa and developing Asia it should be added 1,420 TWh per year in total global energy generation, which represents 5% of last year overall generation.
- In total there is around 12 GW of available potential in sub-Saharan Africa out of which less than 500 MW is used.(4%). Kenya has biggest potential capacity in whole region (3GW) which accounts for 25% of all sub-Saharan region.
- SHP potential in developing Asia is larger than 30 GW out of which 5 GW is already used (14%). India has 12 GW SHP capacity potential but that would be enough to provide only 4% of extra required energy. On the other hand, Nepal could solve energy poverty issue only by using SHP potential. In addition, Afghanistan with its 1.2 GW SHP potential capacity could solve 90% of country's need.

Modern fuel access can result from either improving technology and/or switching to less polluting and more efficient fuel

Options to improve modern fuel access

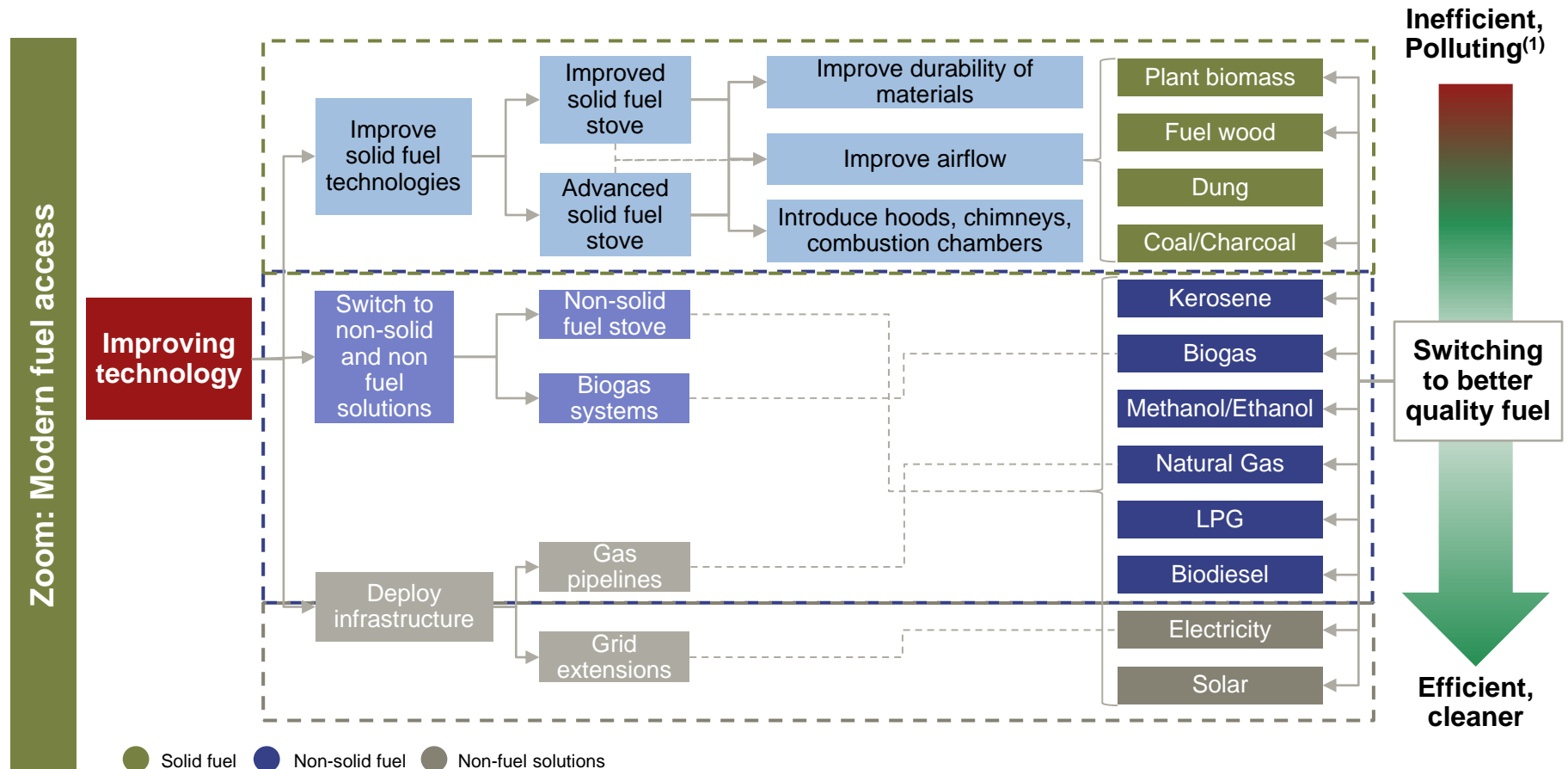

Note: (1) for instance, considering total energy used, the CO2 and particulate emissions per household per day. The switch does not have to occur in the suggested order; (2) Fuel heat content (see slide 14)
 Source: Pictures: Global Alliance for Clean Cookstoves, "Business Plan 2012" (<https://cleancookstoves.org/binary-data/RESOURCE/file/000/000/202-1.pdf>); Fuel Analysis, Comparison & Integration Tool (FACIT) (<http://cleancookstoves.org/technology-and-fuels/facit/index.html#>); A.T. Kearney Energy Transition Institute

In addition to reducing in-house air pollution modern stoves also impact energy efficiency

Segmentation of stove technologies

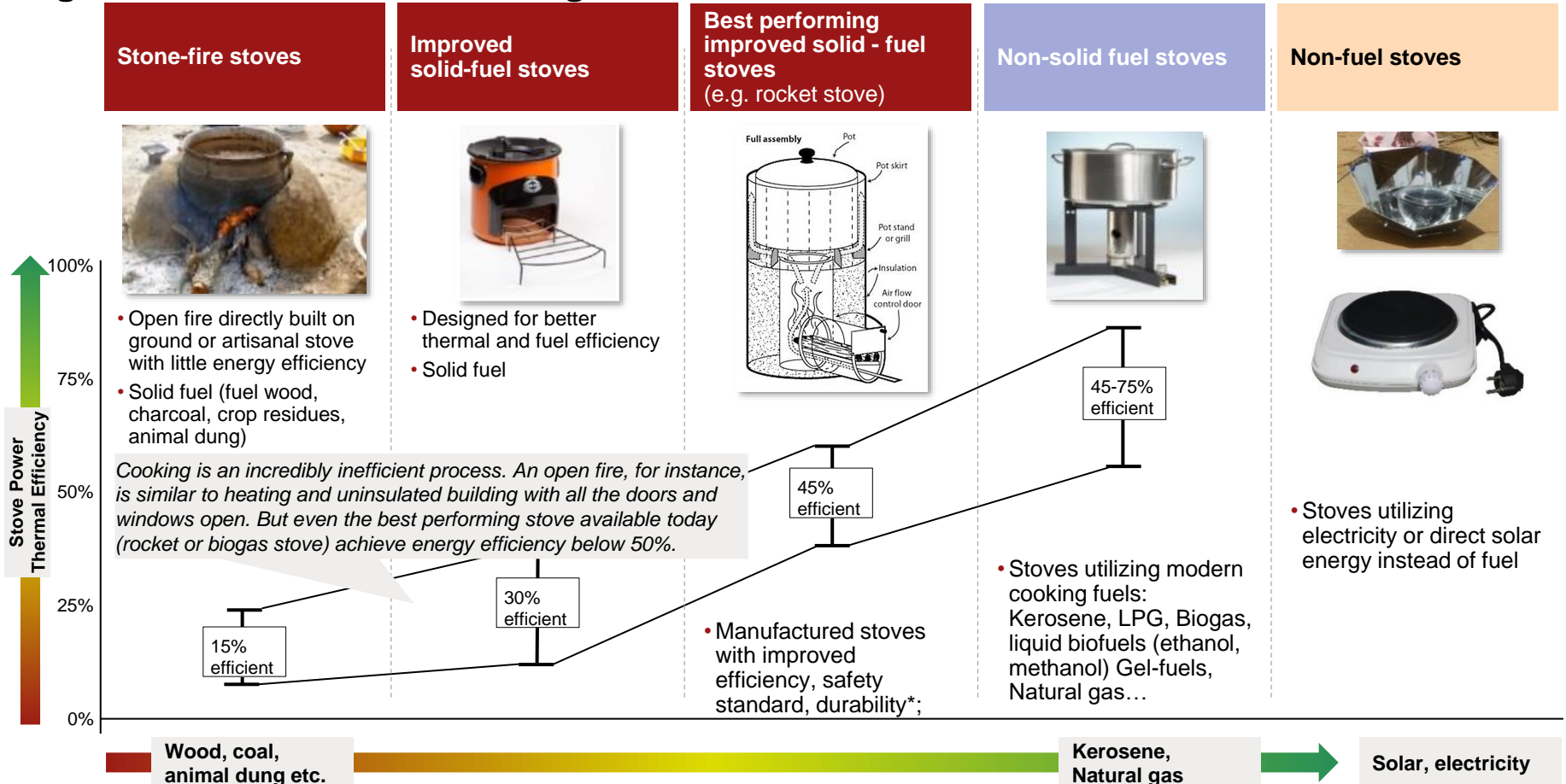

1. Oliver Adria and Jan Bethge, (October 2013), "The overall worldwide saving potential from domestic cooking stoves and ovens"

Source: Urmee et al. (2014), "A review of improved cookstove technologies and programs"

Pictures: Global Alliance for Clean Cookstoves, "Business Plan 2012" (<https://cleancookstoves.org/binary-data/RESOURCE/file/000/000/202-1.pdf>); Fuel Analysis, Comparison & Integration Tool (FACIT) (<http://cleancookstoves.org/technology-and-fuels/facit/index.html#>)

Many of the non-solid fuel technologies entered the deployment phase, with new solutions in the development/demonstration phase

Technology maturity curve for Sub-Saharan Africa, developing Asia and South America

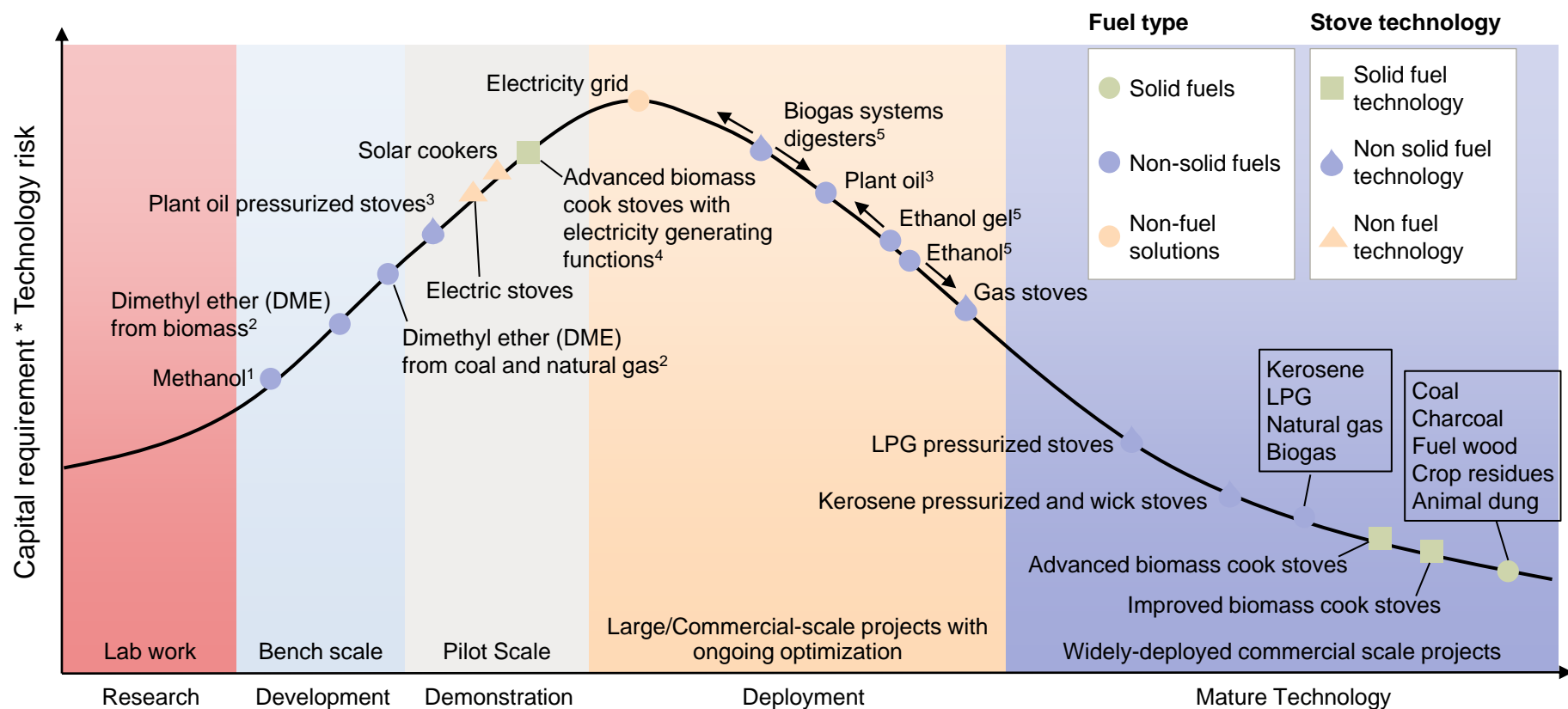

Note: (1) Methanol is very dangerous to use impeding commercialization; (2) Obtained by dehydration of methanol derived from natural gas, coal or biomass; (3) Include coconut, rapeseed, castor, jathropa plant oils; (4). /http://biolitestove.com/about/technology; (5) The stage of deployment varies geographically with Asia and South America further down the curve, and Africa further back the curve.

Source: A.T. Kearney Energy Transition Institute Analysis, IEA (2006), "World Energy Outlook"; Williams, "Toward a Global Clean Cooking Fuel Initiative"; Schlag et al. (2008) "Market Barriers to Clean Cooking Fuels in Sub-Saharan Africa: A Review of Literature"

One of the best low-cost solution promoted by NGOs combines insulated and pressurized cookers with solar and biomass rocket stoves for backup

Integrated cooking system

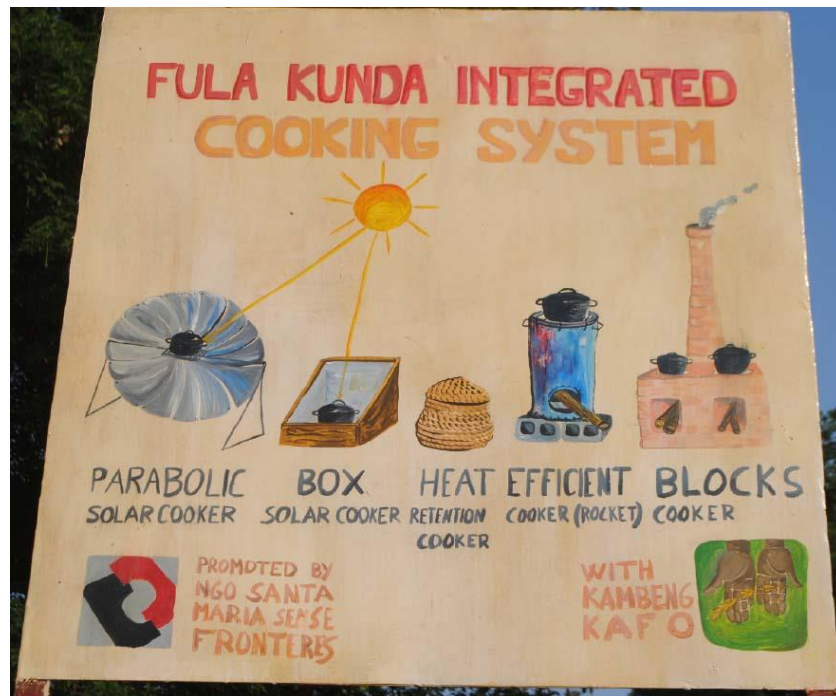

- Tin or aluminum box cooker are easy to build and can use direct as well as indirect solar radiation to heat up the dish when the weather is partly cloudy, while parabolic cookers provides higher energy densities but are generally reserved for large-scale cooking and institutions.
- Once the dish reaches optimal cooking temperature, it is placed in a fireless insulated cookers which maintain temperature for hours and let the meal slowly cook. If available, improved dish sealing can be used to cook under pressure at higher temperature, and vacuum technology can improve insulation compared with traditional tissue-based insulator (picture below)



- Complementary biomass rocket cooker is required to compensate for the most cloudy days.

4. Enabling policies and initiatives



The dynamics affecting energy poverty are numerous and interdependent

Key drivers and factors that influence energy poverty

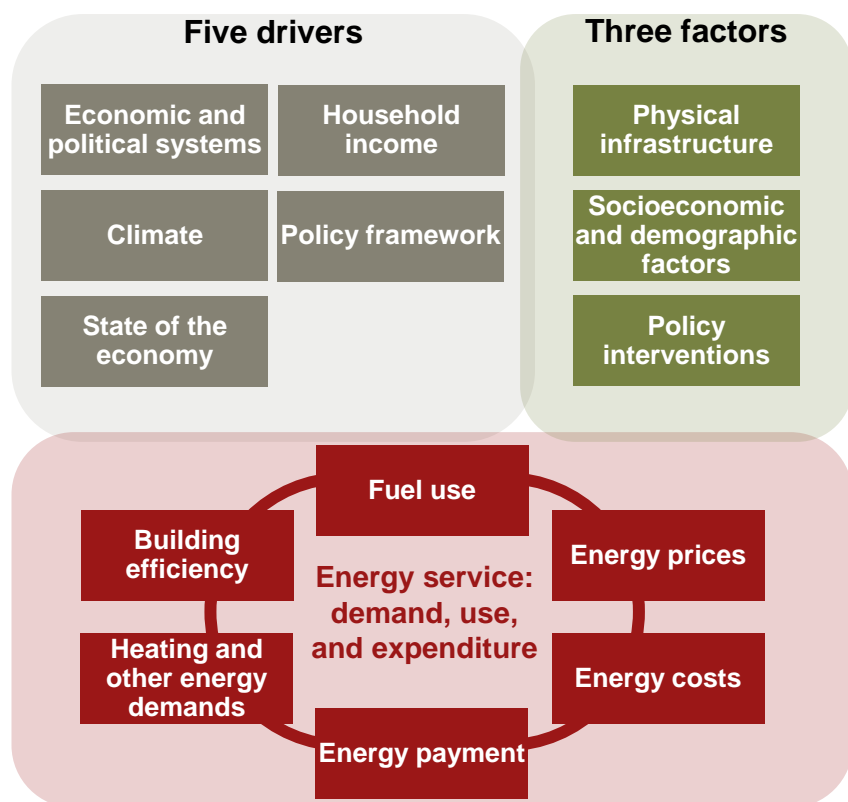

- Energy poverty is the result of a disproportionate share of household expenditures on energy costs (**affordability concerns**) or the inability to access adequate energy service provision (**inadequate energy serviced**).
- **Five drivers** directly or indirectly impact energy poverty. The relative importance of these drivers **vary drastically from country to country and from region to region**.
 - **Economic and political systems** will directly impact energy market development or institutional structures and energy supply.
 - The **climate** will have a different impact in different regions (for example, Europe versus Africa) and directly affect major variables such as total energy demand and building efficiency.
 - The **state of the economy** and **household income** levels will be directly translated to fuel usage as well as energy prices and payments.
 - The **policy framework** will influence the level of support to vulnerable consumers.
- **Three factors** influence energy poverty: providing access to the energy supply, addressing affordability concerns, and promoting energy efficiency measures and public awareness.

Favorable policies and a clear regulatory regime are imperative in addressing challenges associated with sustainable energy development

Mapping RISE to policy frameworks globally^{1, 2}

RISE is a set of indicators to help compare national policy and regulatory frameworks for sustainable energy

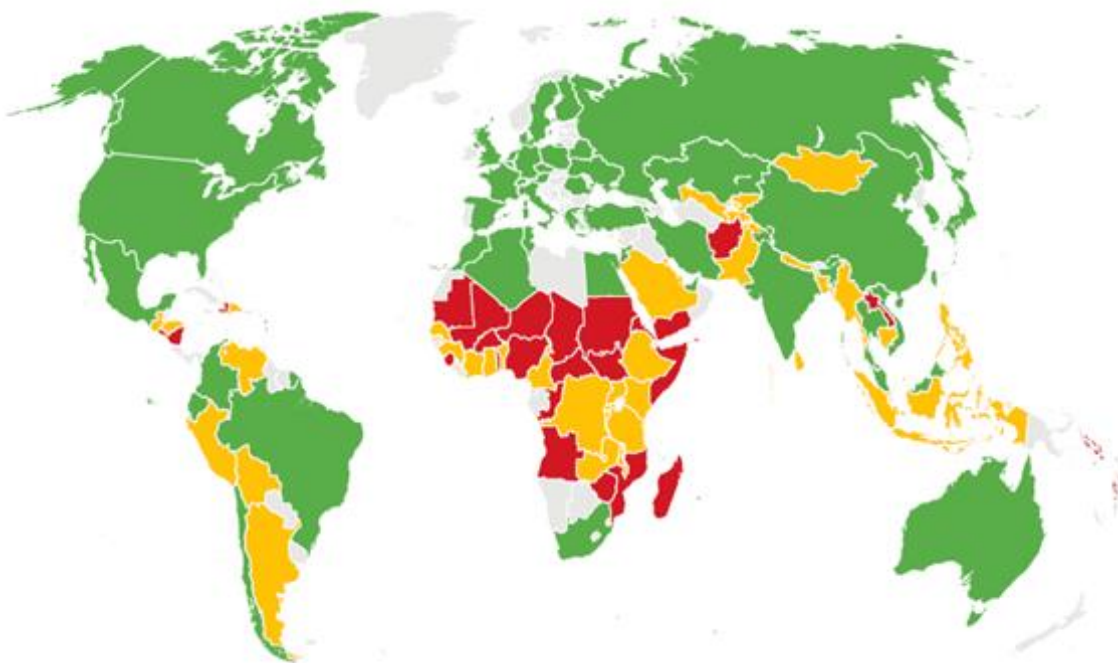

Populations without access to clean fuel
% population (refer to slide 30)

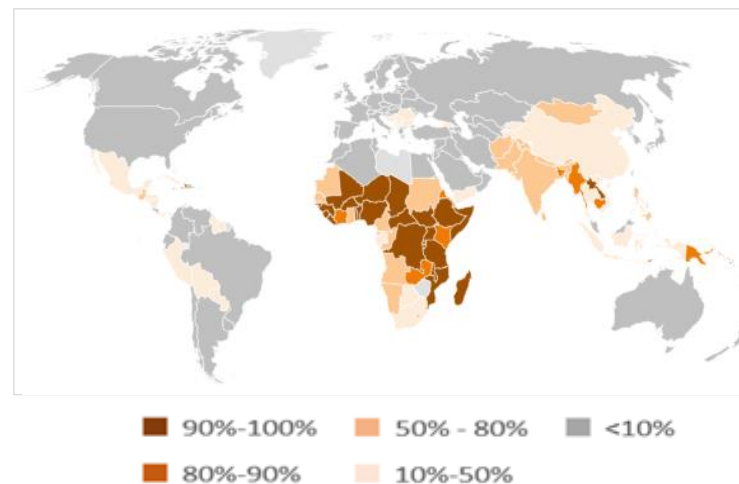

Green Scores of 67–100. Most elements of a strong policy framework to support sustainable energy are in place

Yellow Scores of 34–66. Significant opportunities to strengthen the policy framework exist

Red Scores of 0–33. Few or no elements of a supportive policy framework have been enacted

1. RISE - Regulatory Indicators for Sustainable Energy

2. Developed by World Bank, RISE consists of 27 indicators and 80 sub-indicators covering 111 countries and representing 96 percent of the world population. The World Bank assesses RISE using three energy pillars: access to modern energy, energy efficiency and renewable energy

Source: World Bank – RISE (Regulatory Indicators for Sustainable Energy) rankings report 2016, A.T. Kearney Energy Transition Institute

Sub Saharan Africa has one of the least developed policy environments for supporting energy access

Average energy access scores

Graded on the range of 0 (center) - 100 (outside end)

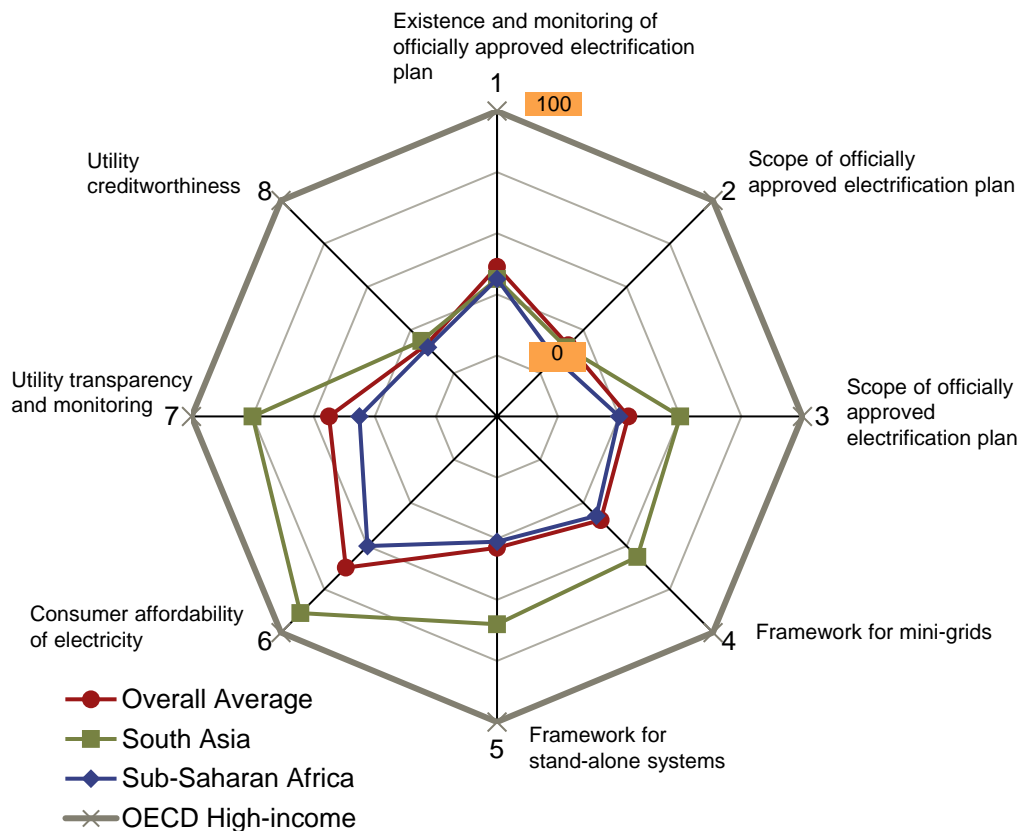

The Energy Access score, as defined by the World Bank, reports on eight major indicators (broken down into further sub-indicators), which capture the quality of policies and regulations in terms of energy access. The key indicators are:

1. Existence and monitoring of an officially approved electrification plan
2. Scope of officially approved electrification plan
3. Framework for grid electrification
4. Framework for mini-grids
5. Framework for stand-alone systems
6. Consumer affordability of electricity
7. Utility transparency and monitoring
8. Utility creditworthiness

Africa fares poorly on these indicators compared with South Asia (the other major region with an energy-access deficit), highlighting weaker policy frameworks. However, many countries have been developing policies and adopting best practices recently.

Vietnam achieved universal access to electricity through the government's unwavering commitment to electrification over two decades

Multi-phase journey towards electrification in Vietnam ¹

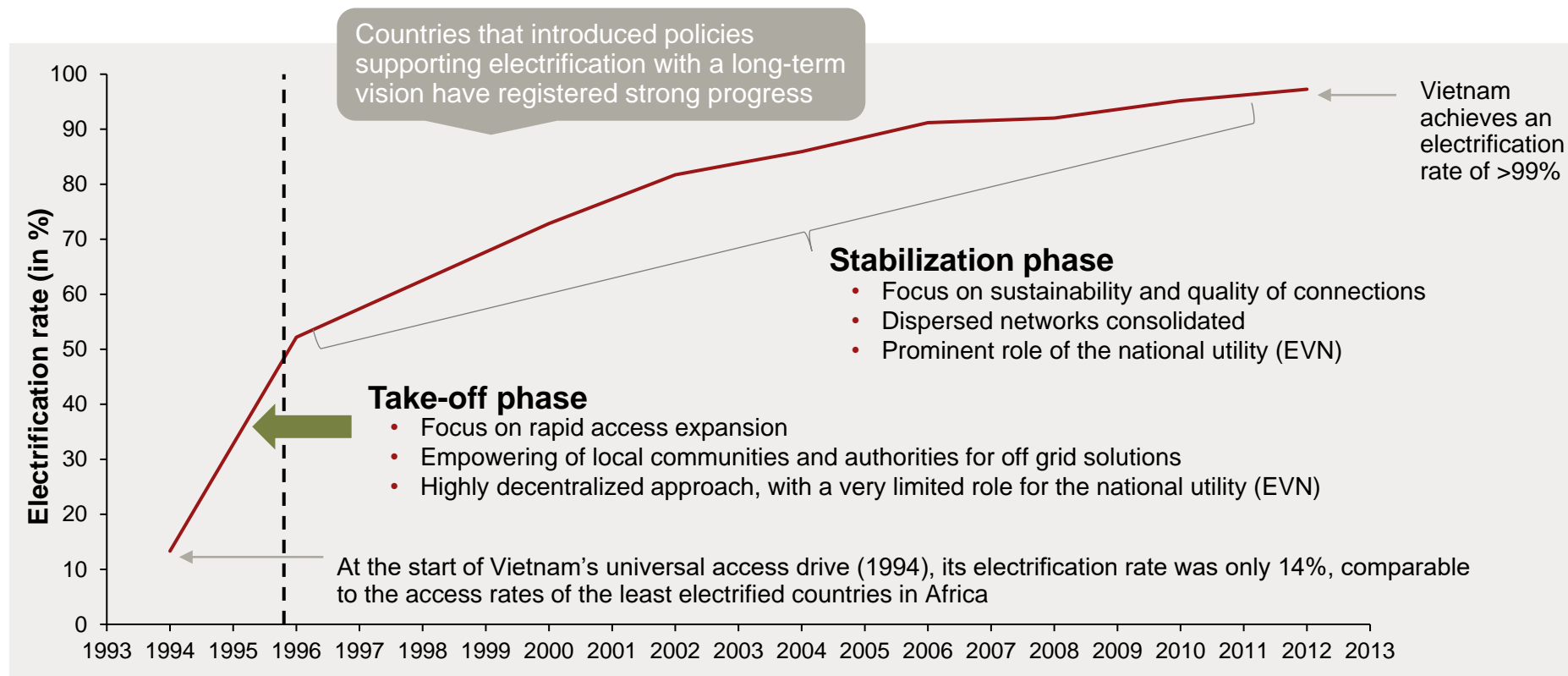

1. By 2009 the country had electrified 96% of its households (from estimated 2.5% in 1975). This high level of electrification is comparable to the People's Republic of China and Thailand, and is remarkable because Vietnam has a lower average income level than either country. The success of Vietnam serves as valuable lessons to pass on, especially for other countries of the Greater Mekong subregion, which seek greater levels of electrification and have similar country profiles to Vietnam – Asian Development Bank
Source: World Bank – STATE OF ELECTRICITY ACCESS REPORT (2017), A.T. Kearney Energy Transition Institute

Bangladesh complemented grid-extension initiatives with an SHS1 model for remote households, leading to a rapid increase in energy access

Timeline of IDCOL's SHS (off grid) program in Bangladesh^{2, 3}

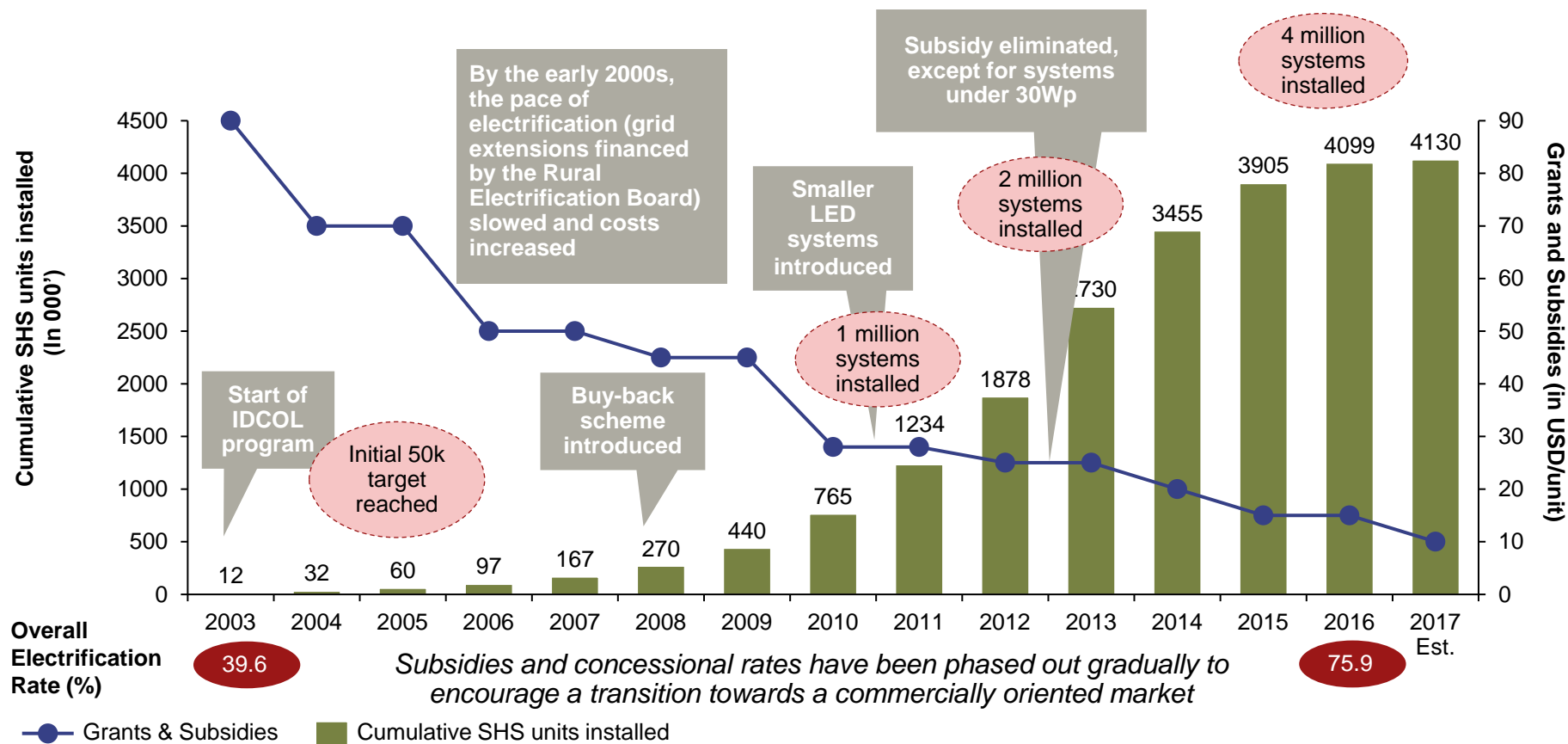

1. Solar Home system, 2. Infrastructure Development Company Limited; a government-owned non-bank financial institution that finances renewable infrastructure projects, 3. Despite significant challenges in its power sector, Bangladesh has succeeded in developing the largest and most dynamic national off-grid electrification program in the world, yielding lessons that may be applicable to other countries considering off-grid solutions to improve access to electricity – World Bank

Bangladesh set up an ownership-based model “IDCOL” to promote solar home systems leveraging microfinance institutions network and subsidies

(1) IDCOL’s ownership model for Solar Home System (SHS)

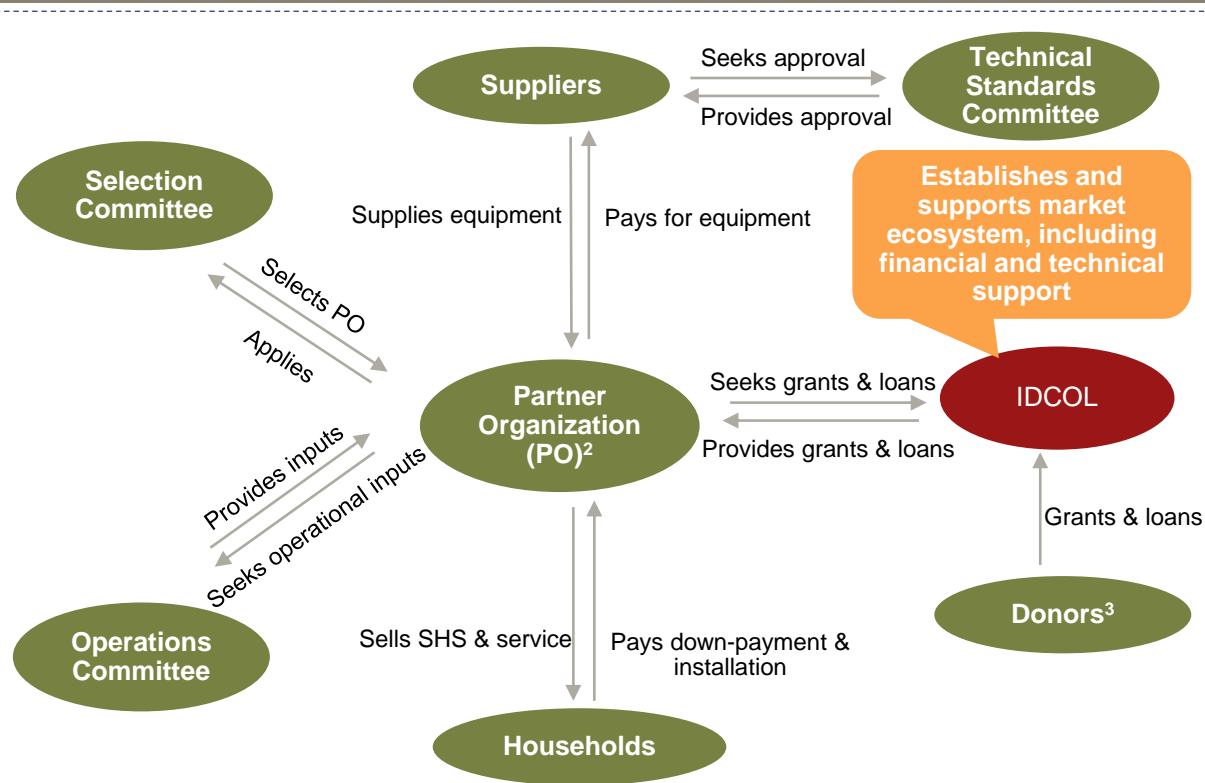

Salient features:

- The government program utilized the extensive, pre-existing reach of microfinance institutions across Bangladesh and benefited from the country’s high population density
- The SHS affordability barrier was lowered by a combination of consumer credit, subsidies, and product choices
- Subsidies were set in a progressive manner, that is: smaller systems, being more affordable to poorer populations, received higher subsidies than larger systems
- Emphasis on quality assurance (IDCOL-verified equipment and services) helped build consumer trust

Impact:

- Total saving in terms of reduction in kerosene use: 1.14 million tons worth USD 411 million
- SHSs are now locally manufactured compared with only one component (batteries) initially

Key lessons:

- A local government-sponsored champion is important to promote off grid programs, as traditional funding sources might be unwilling to fund such loans and solutions
- Technical and financial solutions should match customers’ ability to pay

1. IDCOL: Infrastructure Development Company Limited, 2. These partner organizations could be non-government organizations, micro-finance institutions, societies, foundations, and/or private entities responsible for implementing the program, 3. World Bank, GEF, GIZ, KfW, ADB, IDB, GPOBA, JICA, USAID and DFID

Source: IDCOL (2017), World Bank - Scaling Up Access to Electricity: the case of Bangladesh (2014), A.T. Kearney Energy Transition Institute

Delivering sustainable energy access for all is a priority in International Development Agenda

Timeline of some major international policy initiatives

Not exhaustive

<p>2008 OFID's Energy for the Poor Initiative</p> <p>OPEC acknowledged energy as essential for poverty eradication, sustainable development and mandated OFID (OPEC fund for international development) to intensify efforts in this area. In June 2012, OFID's Council of Ministers approved a US\$1 billion revolving fund dedicated to the purpose.</p>	<p>2012 Global Electricity Initiative</p> <p>Partnership established between the World Energy Council, the World Business Council for Sustainable Development and the Global Sustainable Electricity Partnership. The objective is to encourage action and cooperation between electricity utilities to achieve electricity-access for all people by 2030.</p>	<p>2013 Power Africa</p> <p>Launched by the United States government, Power Africa aims to add more than 30,000 MW of clean and efficient electricity-generation capacity throughout sub-Saharan Africa and to increase electricity access by adding 60 million new home and business connections.</p>	<p>2015 African Renewable Energy Initiative</p> <p>Endorsed by African Heads of State, Ministers of Environment, the G7 and G20, as the continent's a major contribution to Conference of Parties (COP21). The target is to produce 300 gigawatts (GW) of electricity for the continent by 2030.</p>	<p>2016 Electrification Financing Initiative</p> <p>Launched by the European Commission to increase energy access and off-grid solutions for poor, remote communities in rural sub-Saharan Africa. The current corpus is EUR 115 million, to be disbursed in various options from convertible grants to structured debt and traditional equity.</p>
<p>2008 Energy for All Initiative</p> <p>Promoted by Asian Development Bank and aimed to provide modern energy to an additional 100 million people in the region by 2015.</p>	<p>2012 International Year of Sustainable Energy for All (SE4ALL)</p> <p>Launched by the United Nations General Assembly, the initiative aims to achieve universal access to electricity and cleaner cooking fuels by 2030.</p>	<p>2015 Energy Africa campaign</p> <p>Launched by the UK's Department for International Development, the Energy Africa campaign aims to boost electricity access in Africa by encouraging the use of solar energy in rural households. Its objectives are to increase investment in off-grid energy firms, overcome regulatory barriers, foster innovation and accelerate the delivery of solar energy systems.</p>	<p>2015 The New Deal for Energy in Africa</p> <p>Developed by the African Development Bank, this initiative aims to achieve universal access to electricity by 2025 by accelerating energy investments. This will require providing 160 GW of new capacity, 130 million new on-grid connections, 75 million new off-grid connections and providing 150 million households with access to clean cooking solutions..</p>	<p>2017 Clean Energy Transitions Programme</p> <p>The IEA's €30 million, multi-year plan, backed by 13 countries, is designed to support clean energy transitions. It provides cutting-edge technical support to governments in countries where energy policy could have a significant impact on the speed of the global transition towards more sustainable energy production and use. This includes reductions in GHG emissions and greater access to energy.</p>
<p>2010 Global Alliance for Clean Cookstoves</p> <p>Hosted by the UN Foundation, this public-private partnership seeks to enable an additional 100 million homes to adopt clean and efficient stoves and fuels by 2020.</p>	<p>2012 Africa Clean Cooking Energy Solutions Initiative</p> <p>Under the auspices of the World Bank and the Africa Energy Group, this initiative promotes large-scale, enterprise-based dissemination and adoption of clean-cooking solutions in sub-Saharan Africa.</p>			

Energy policies are essential for eradicating energy poverty and activating the necessary levers at the various energy maturity stages

Policy types for the energy sector

Indicative

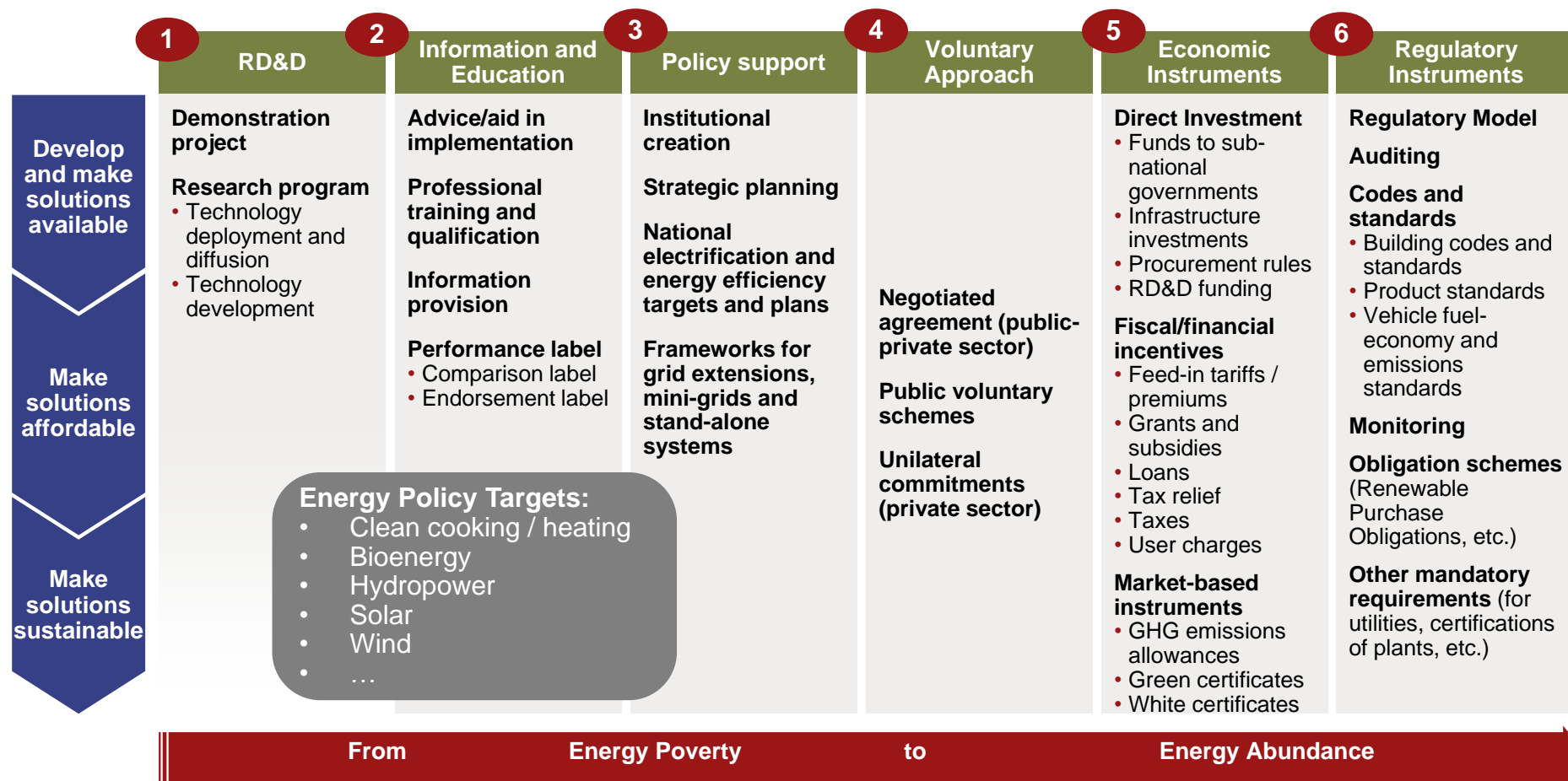

Policy support should evolve as markets mature, allowing better alignment between priorities and enablers

Long-term evolution of policy and regulatory support^{1, 2}

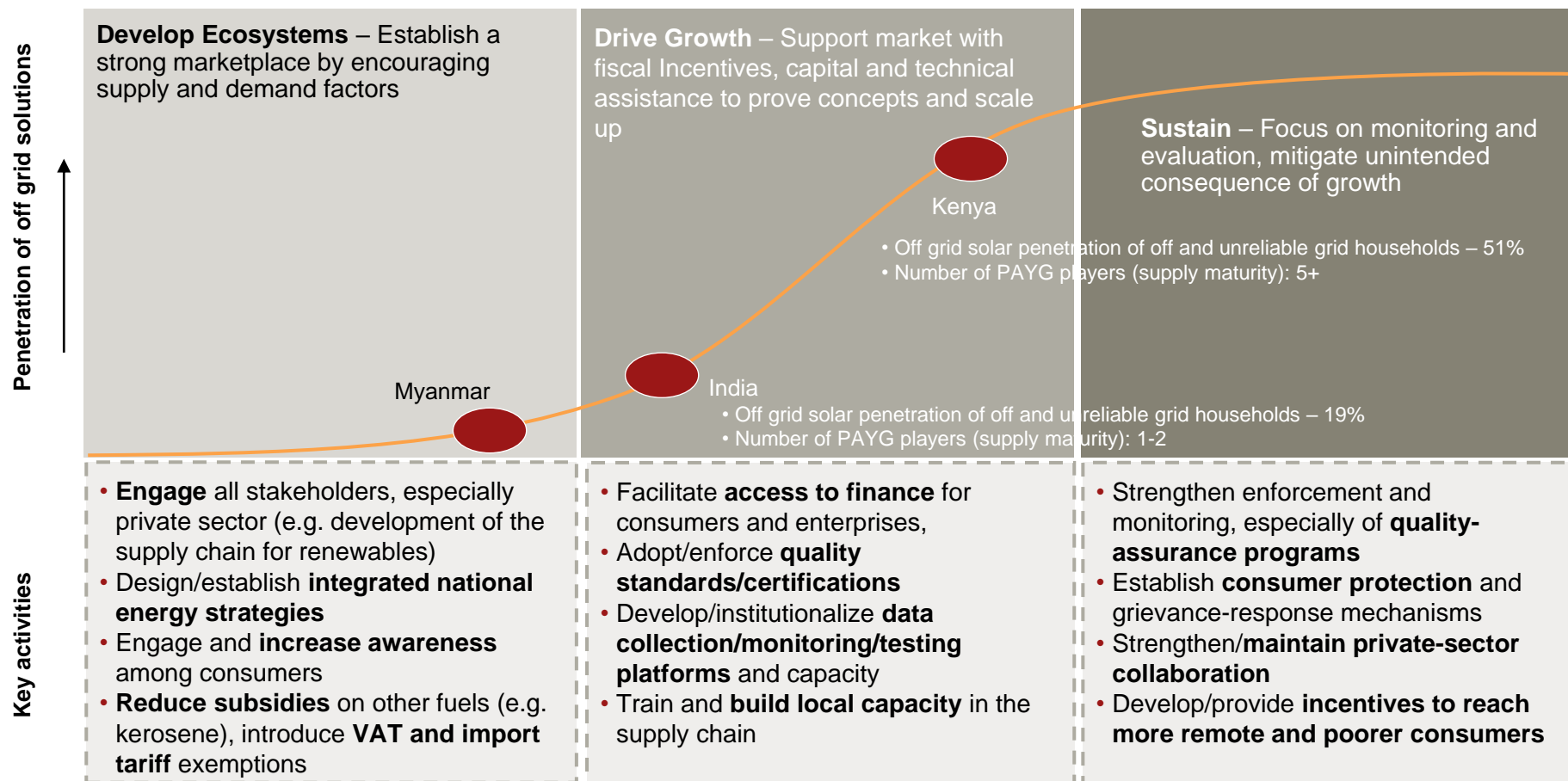

1. Indicative progress shown for certain countries' off-grid solar markets, 2. PAYG: Pay-as-you-go

Source: World Bank Group - Lighting Global Program (2018), The 2018 Global Off-Grid Solar Market Trends Report, A.T. Kearney Energy Transition Institute

Industry value chain, through which energy services are delivered to end consumers, is at the core of the energy-access ecosystem

Energy access ecosystem¹

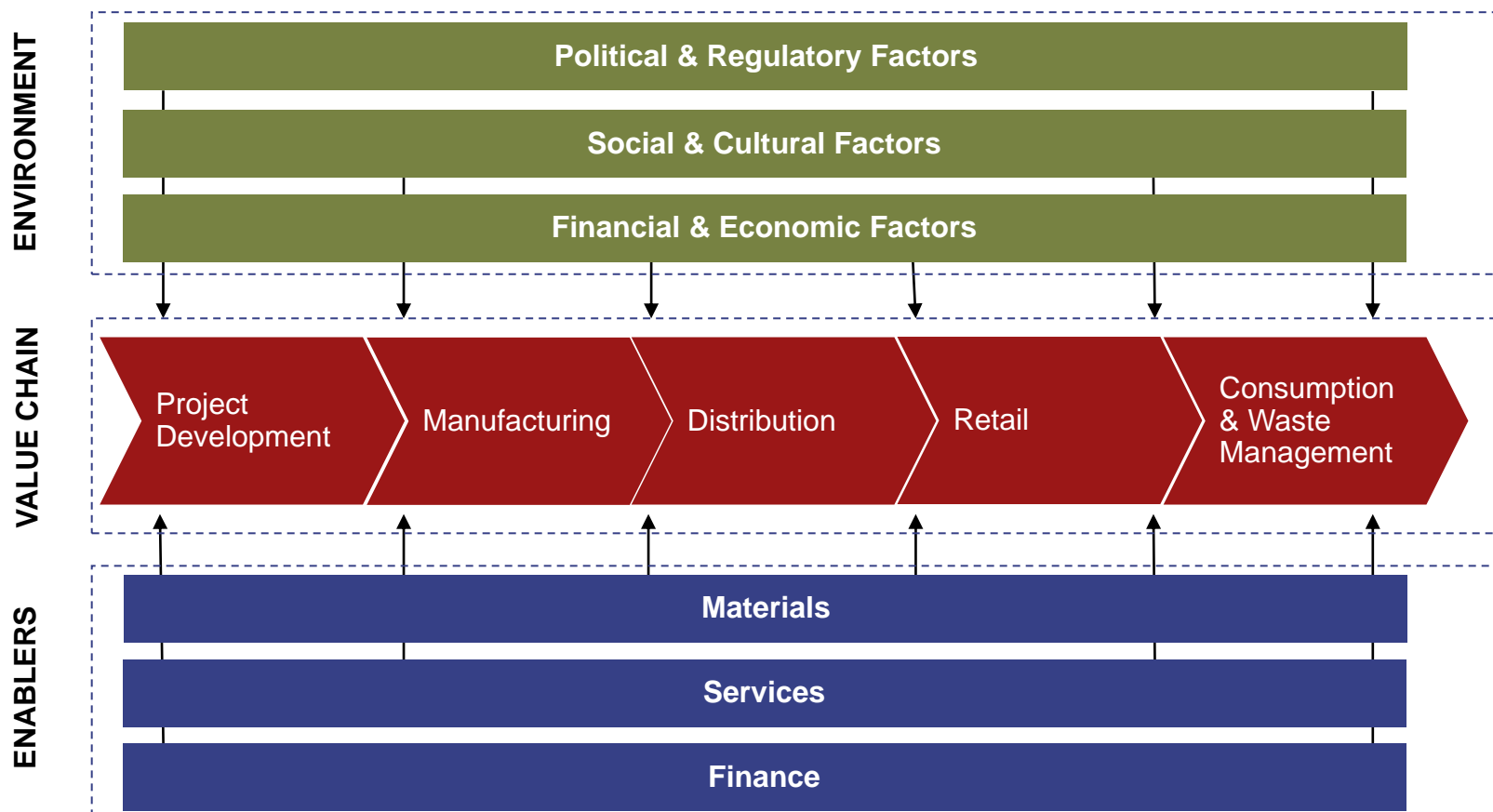

1. Adapted from EU Energy Initiative – Partnership Dialogue Facility (EUEI PDF)
Source: Practical Action Consulting (PAC) and EUEI PDF - Building Energy Access Markets (2015), A.T. Kearney Energy Transition Institute

Multiple stakeholders can support efforts to expand access to clean, reliable and affordable energy

Key stakeholders

Not exhaustive

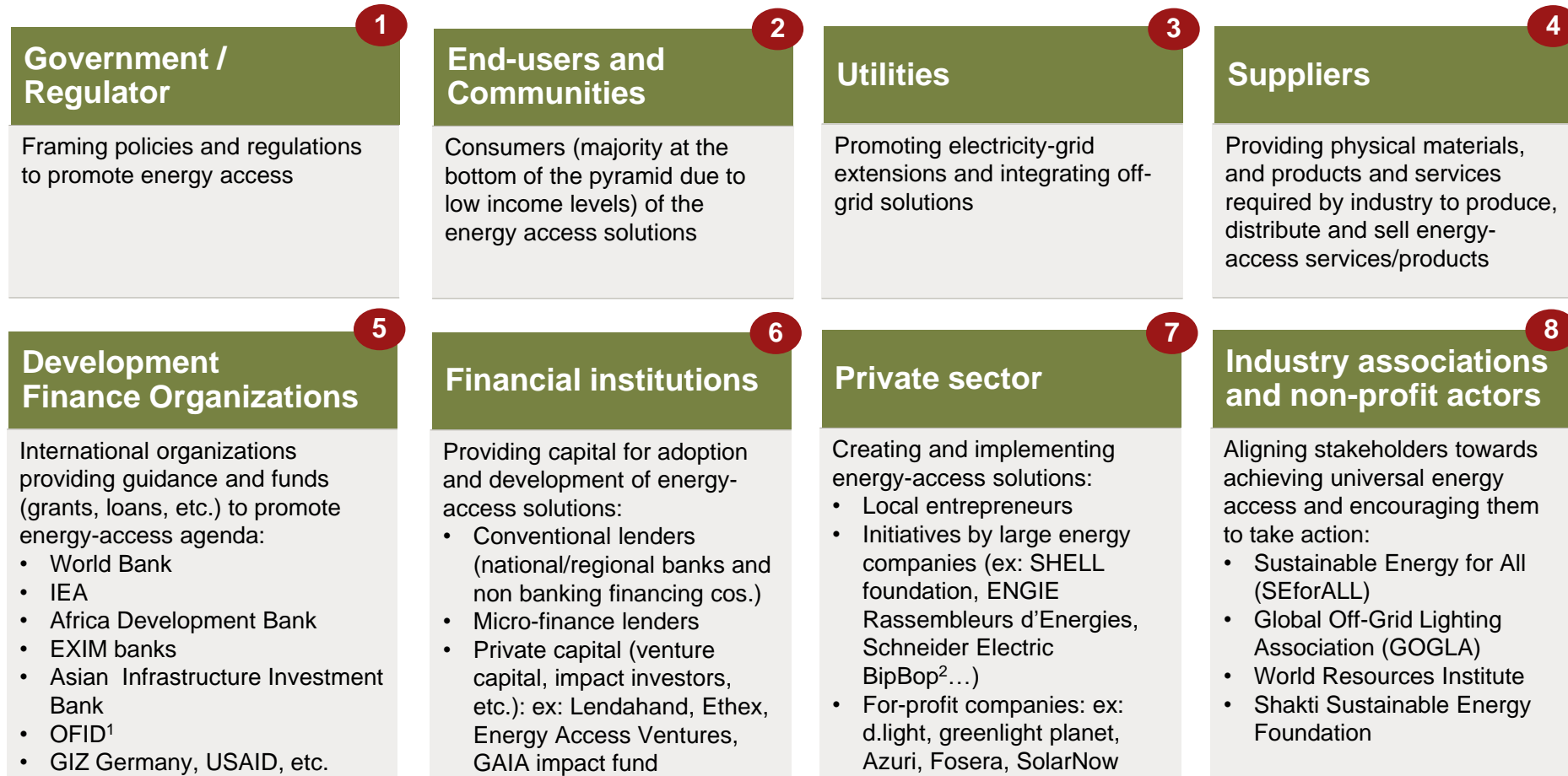

1. OPEC Fund for International Development (OFID), 2. Business, Innovation & People at the Base Of the Pyramid
Source: Practical Action Consulting (PAC) and EUEI PDF - Building Energy Access Markets (2015), A.T. Kearney Energy Transition Institute

Stakeholders can strengthen energy access ecosystem by supporting different focus areas

Not exhaustive

Key support pillars					
	Policy support	Business Development Support	Technical assistance	Financial assistance	Awareness raising
	Enabling supportive environment for the development of energy access solutions	Increased capacity of value chain companies to develop / extend their business models	Increased capacity of value chain companies on technical issues	Grant / loan / equity financing	Helping end users increase their uptake of energy products
Government / Regulator	√			√	√
End – user & communities					√
Utilities	√	√	√	√	√
Suppliers			√		
Development finance organizations		√		√	
Financial institutions				√	
Private sector		√	√	√	√
Industry association / non profit actors		√	√		√

√ - denotes presence of the stakeholder in a specific support pillar

Projects sponsored by multilateral organizations promote energy access through efficient deployment and by strengthening existing energy systems

Indicative

African Development Bank

- 346 power projects funded amounting to 18,883.985 UA millions. 1 UA=1 SDR (IMF Special Drawing Rights)



OFID¹

- Cumulative value of energy projects approved amounted to \$4,769 million, or 23% of the organization's total approvals (2017)

Project description

- Extend grid as part of Electricity Access Improvement Project (SEAP) in Rwanda. Project will benefit an estimated 25,438 households (127,000 people), 179 schools, 29 health centers, and 25 sector administration offices (supporting 2018 goal of 70% electrification)

Project description

- Rehabilitation of high-priority circuits across Dominican Republic and installation of around 1,050 km of distribution networks, with the aim of reaching 607,500 users

Funding

- UA2.22 million funding by African Development Fund; Implementation by Energy Development Corporation

Funding

- \$75 million from OFID (total project cost: \$165 million); co-financiers: CAF, Government of Dominican Republic

Application areas

Efficient deployment of existing solutions at scale ²	Efficiency and reliability of the energy system
Innovation and new solutions	Financial resources
Linkages with local firms and social entrepreneurs	Knowledge and skills transfer

Application areas

Efficient deployment of existing solutions at scale	Efficiency and reliability of the energy system
Innovation and new solutions	Financial resources
Linkages with local firms and social entrepreneurs	Knowledge and skills transfer

1. OPEC Fund for International Development (OFID), 2. Efficient deployment refers to grid extensions providing additional connections
Source: African Development Bank website, OFID website, A.T. Kearney Energy Transition Institute analysis

Financial support for conventional and innovative energy solutions generates significant socio-economic and environmental benefits

Indicative

Shell Foundation (SF)

- Independent UK-registered charity established by the Shell Group in 2000 to create and scale new solutions to global development challenges



World Bank

- ~\$1.5 billion portfolio encompassing generation, transmission, distribution, off-grid service provision, technical assistance in power sector

Project description

- Creating, innovating and scaling-up of decentralized and low-cost energy solutions, such as solar lighting, biogas, biomass gasification, etc. Example projects: consumer affordability (M-KOPA), last-mile distribution (Dharma Life)

Funding

- Endowment of \$250 million from the Shell Foundation (SF); SF has supported over 100 entrepreneurs and organizations in the energy-access space, deploying nearly \$74 million and benefiting 54 million people

Application areas

Efficient deployment of existing solutions at scale ²	Efficiency and reliability of the energy system
Innovation and new solutions	Financial resources
Linkages with local firms and social entrepreneurs	Knowledge and skills transfer

Project description

- In March 2018, World Bank approved International Development Association (IDA) credit to support Ethiopia's goal of achieving universal electricity access by 2025

Funding

- The \$375 million program has the potential to leverage additional multi-donor financing and involvement. These funds will support Ethiopia's National Electrification Program to provide 1 million last mile household connections

Application areas

Efficient deployment of existing solutions at scale	Efficiency and reliability of the energy system
Innovation and new solutions	Financial resources
Linkages with local firms and social entrepreneurs	Knowledge and skills transfer

Corporate impact funds and initiatives prioritize the development of local ecosystems and financially sustainable solutions

Indicative

ENGIE Rassembleurs d'Energies

- Corporate-impact venture fund investing in profitable local enterprises providing sustainable energy-access solutions to poor communities



Schneider Electric's BipBop1

- BipBop program has been created to bring safe, clean electricity to the people who need it most worldwide (27 projects in 17 countries)

Project description

- Social and environmental impacts are the most important selection criteria; initiative encourages social entrepreneur involvement. Examples: SIMPA (India, PAYG SHS²), SIMGAS (Africa, clean cooking)

Funding

- €50 million endowment; €16 million invested in 18 projects (by 2016)

Application areas

Efficient deployment of existing solutions at scale ²	Efficiency and reliability of the energy system
Innovation and new solutions	Financial resources
Linkages with local firms and social entrepreneurs	Knowledge and skills transfer

Project description

- BipBop program, involving local communities and stakeholders, addresses three key issues: the lack of affordable products and appliances; the lack of financial resources available for innovative energy entrepreneurs; and the shortage of skills and expertise

Funding

- Created with the backing of Crédit Coopératif and PhiTrust and with an initial capitalization of €3 million

Application areas

Efficient deployment of existing solutions at scale	Efficiency and reliability of the energy system
Innovation and new solutions	Financial resources
Linkages with local firms and social entrepreneurs	Knowledge and skills transfer

1. Business, Innovation & People at the Base Of the Pyramid, 2. Pay-as-you-go Solar home system
Source: ENGIE website, Schneider Electric website, A.T. Kearney Energy Transition Institute analysis

Multiple delivery models have evolved to service customers in low-income markets such as Africa

Business Model	Description	Units sold / Customers per business ¹	Jobs created ¹
Retail	<ul style="list-style-type: none"> Implemented through multi-level supply chain (accounts for 30-50% of the product price) Large rural sales force required and transactions are mostly cash-based Product life of 2-3 years 	50,000-300,000	<ul style="list-style-type: none"> Full time: 40-50 Distributors: 40-50, Retailers: 500-3,000
PAY-as-you-go (PAYG)	<ul style="list-style-type: none"> The supplier of the solar product also provides consumer finance for the product Consumer makes a down payment and the remaining repayment fee is dependent on the cost of the system and duration of the repayment schedule Payments are usually made via mobile money; alternative methods include scratch cards, mobile airtime and cash 	30,000-100,000	<ul style="list-style-type: none"> Full time: 1,000 Commission based agents: 1,000
Consumer Financing (FI)	<ul style="list-style-type: none"> The solar-product supplier provides products and associated services while the partner Financial Institution (FI) provides consumer financing and collects repayments FI is experienced in vetting consumers for financial risk and can offer financing at a lower rate and longer duration 	2,000	<ul style="list-style-type: none"> Full time: 30 Part time technicians: 30
Micro-grid	<ul style="list-style-type: none"> These grid systems are technically most effective when many customers can be connected within a 1km radius Characterized by high capital costs and moderate/high operational costs Tariffs are designed to recover costs and generate returns, but payback periods for mini/micro grids are lengthy (3-7 years) 	500	<ul style="list-style-type: none"> Full time: 10-50 Point of sale, technicians: 10-20
Fee for service	<ul style="list-style-type: none"> Similar to the mini/micro-grid system, with the difference being that electricity services are provided through standalone systems, as opposed to distribution networks. Ownership of the systems is not transferred to the customer and the business/project is entirely responsible for system maintenance and replacement. 	1,000	<ul style="list-style-type: none"> Full time: 40 Part time technicians: 10

1. Indicative figures, on the basis of interviews/projects' data in East Africa (Tanzania, Rwanda, Kenya and Uganda)

Analysis of projects in east Africa indicates that certain delivery models are more effective than others in specific market segments

Comparison of delivery models for solar PV by market segment^{1, 2}

Multi-tier matrix for measuring access to household electricity services based on the type of appliances used

	Power capacity, Wp	Delivery Model	Retail Price (\$)	Deposit (\$)	Daily fee (\$)	Monthly cost (\$)
Tier 0.5‡ Task lighting ONLY	~ 0.5	Retail	5.5 - 10			
		Fee for Service				
Tier 1 Task lighting AND Phone charging	3	Retail	30 - 60			
		Fee for Service				
Tier 1.5‡ General lighting AND Phone charging	~ 8 - 15	PAYG		19 - 35	0.2 - 1.25	6 - 38
		Fee for Service				
Tier 2 General lighting AND Phone charging AND Television	~ 30 - 50	PAYG	400	62	0.6	18
		Consumer Financing (FI)				
Tier 2.5‡ Tier 2 AND any medium-power appliances	~ 80 - 200	PAYG		18 - 25	0.8 - 1.2	25 - 35
		Fee for Service				
Tier 3 Medium-power productive use/income generation appliances	up to 400	Fee for Service		90	0.6 - 0.7	18-20

■ Retail
 ■ Fee for service
 ■ Pay-as-you-go (PAYG)
 ■ Consumer Financing (via financial institution)

1. Modified (modified tiers depicted by ‡) version of World Bank's Multi-tier Framework;

2. Information is based on the findings from Energy & Environment Partnership (EEP) supported solar PV projects in east Africa

The off-grid solar market has witnessed a rise in innovative financing mechanisms, such as Pay-as-you-go (PAYG)

PAYG business model

Growth in mobile money and financial inclusion ecosystem in low income segment provides tailwind for PAYG adoption

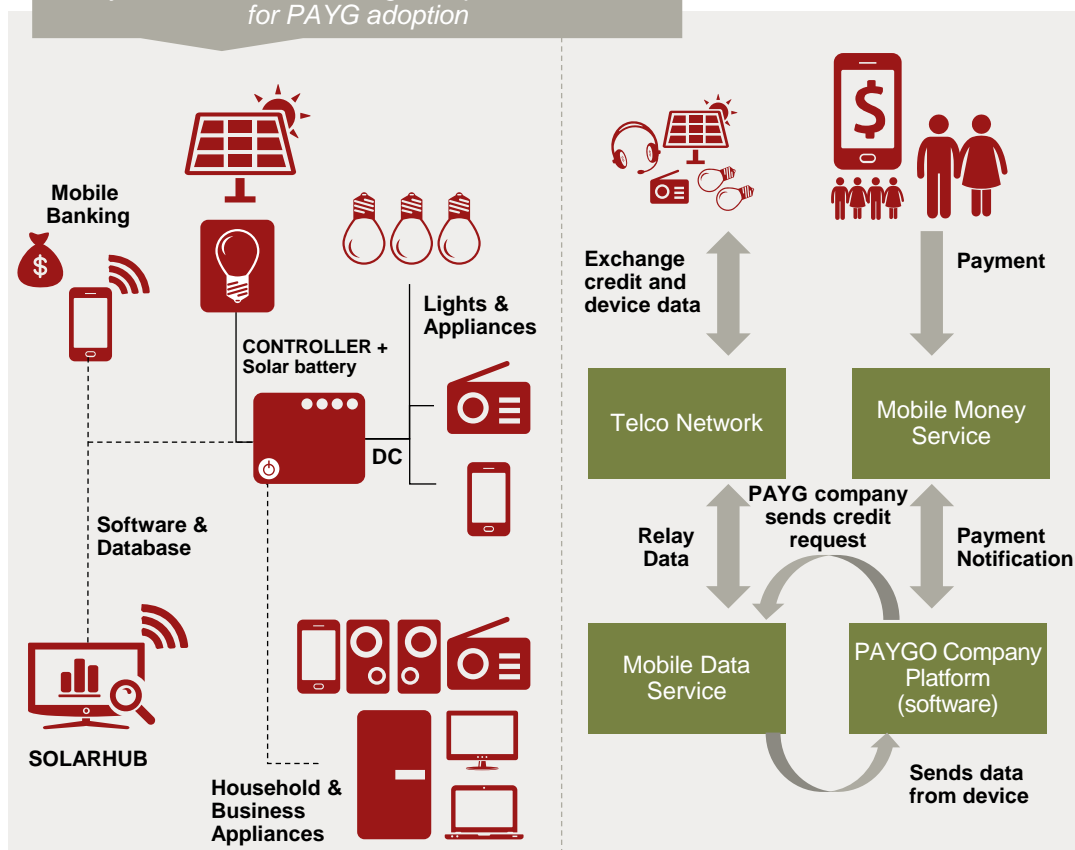

- PAYG is a business model that **allows users to pay for their product via an embedded consumer financing**:
 - A PAYG company will typically **offer a solar product** (predominantly solar home systems and multi-light pico-devices)
 - The customer makes a **down payment, followed by regular payments for a term** ranging from six months to eight years
 - **Payments are usually made via mobile money**, though there are alternative methods that include scratch cards, mobile airtime and cash
- PAYG businesses raised \$773 million (2012-17), **equal to ~85% of all funds raised in the off grid solar market**
- Despite strong growth, some challenges remain:
 - **Larger working capital** requirements
 - **Asset quality**: as PAYG players search for more customers, their bad debt ratio rises
 - Limited economic engine: **limited ability of customers** to pay for upgraded/additional services
 - **Data and privacy**: potential risks associated with data assets and their use

PAYG model has only been extensively deployed in east Africa, but Asia offers a significant growth potential

Presence of PAYG players and share of the PAYG market by country

Left: number of players; Right: % cumulative unit sales; n=11 players (2013-17)

Investments in the PAYG market are highly concentrated, with just four companies accounting for 67% of total PAYG investment (2012-17)

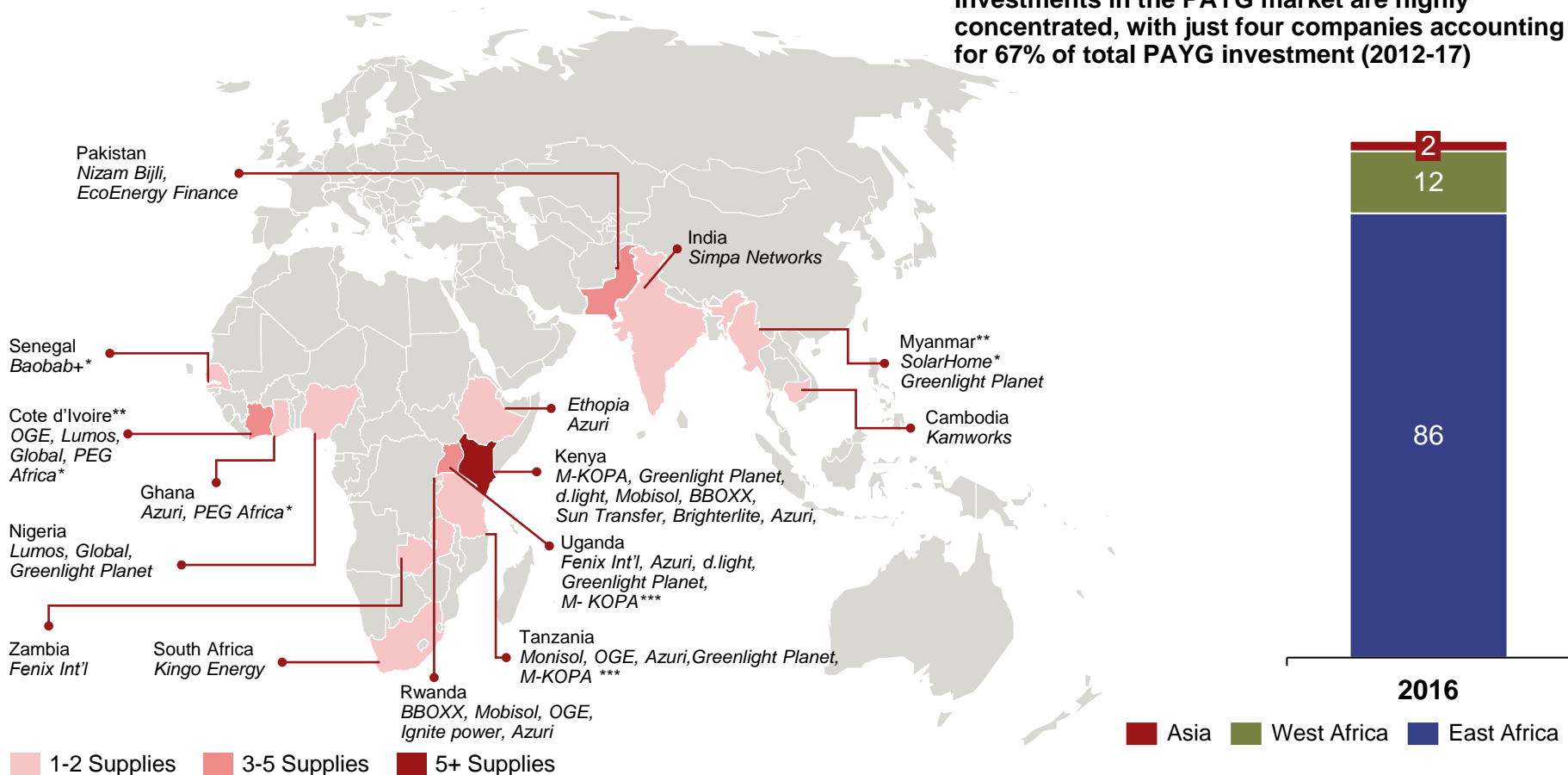

Appendix and Bibliography

Acronyms

- **AC:** alternated current
- **CAPEX:** capital expenditure
- **CFL:** compact fluorescent light
- **COPD:** chronic obstructive pulmonary disease
- **CPV:** concentrated photovoltaic
- **CSP:** concentrated solar power
- **DC:** direct current
- **EDI:** energy development index
- **ESMAP:** Energy Sector Management Assistance Program
- **EU:** European Union
- **FI:** Consumer Financing
- **GDP:** gross domestic product
- **GHG:** greenhouse gas
- **GOGLA:** Global Off-Grid Lighting Association
- **GW:** gigawatt
- **HAP:** household air pollution
- **HDI:** human development index
- **IBRD:** International Bank for Reconstruction and Development
- **IDA:** International Development Association (World Bank)
- **IDCOL:** Infrastructure Development Company Limited (Bangladesh)
- **IEA:** International Energy Agency
- **IPCC:** Intergovernmental Panel on Climate Change
- **IRENA:** International Renewable Energy Agency
- **kgoe:** kilogram of oil equivalent
- **kW:** kilowatt
- **kWh:** kilowatt-hour
- **LCOE:** levelized cost of the electricity
- **LED:** light emitting diode
- **LPG:** liquified petroleum gas
- **MEPI:** multidimensional energy poverty index
- **MJ:** megajoule
- **MW:** megawatt
- **NGO:** non-governmental organization
- **OECD:** Organization for Economic Co-operation and Development
- **OFID:** OPEC Fund for International Development
- **OPEC:** The Organization of the Petroleum Exporting Countries
- **PAYG:** pay-as-you-go
- **PM:** particulate matter
- **PV:** Photovoltaic
- **R,D&D:** Research, Development & Demonstration
- **RET:** renewable energy technologies
- **RISE:** Regulatory Indicators for Sustainable Energy (World Bank)
- **ROW:** rest of the world
- **SDR:** IMF Special Drawing Rights
- **SEforALL:** Sustainable Energy for All
- **SHP:** small-hydro potential
- **SHS:** solar home system
- **TWh:** terawatt-hour
- **UN:** United Nations
- **UNESCO:** United Nation Educational, Scientific and Cultural Organization
- **USAID:** The United States Agency for International Development
- **VAT:** Value added tax
- **WEO:** world energy outlook
- **WHO:** World Health Organization
- **WHS:** wind home system

Bibliography (1/3)

- African Development Bank [link](#)
- Beltran, A. (2013), *El tiempo de la familia es un recurso escaso: ¿cómo afecta su distribución el desempeño escolar?* *Apuntes Revista de Ciencias Sociales*, 72: 117-56
- Bhattacharyya (2014), *Mini-Grids for Rural Electrification of Developing Countries, Analysis and case study from South Asia*
- Blechinger (2013), *GIZ Mini-grid workshop, “Hybrid Mini-Grids: A Huge Market for Rural Electrification and Island Energy Supply”*
- Bouzarovski S., Petrova S. (2015), *A global perspective on domestic energy deprivation: Overcoming the energy poverty–fuel poverty binary*
- d. light SOLAR (2014), *The Energy Access Imperative*
- Energy & Environment Partnership (EEP) / Southern & East Africa (2016) – *Solar PV business models in East Africa report*
- Energy Poverty EU [link](#)
- ESMAP (2001), *“Best practice manual: promoting decentralized electrification investment”*
- ESMAP (2012), *“Sustainable Energy for All (SE4ALL)”*
- European Commission (EC) (2015), *Selecting Indicators to Measure Energy Poverty*
- Fuel Analysis, Comparison & Integration Tool (FACIT) (<http://cleancookstoves.org/technology-and-fuels/facit/index.html#>)
- Global Alliance for Clean Cookstoves, *“Business Plan 2012”* (<https://cleancookstoves.org/binary-data/RESOURCE/file/000/000/202-1.pdf>)
- Grupp, M. (2004), *Domestic cooking appliances in developing countries - Economic and environmental aspects* [link](#)
- Hills, J. (2012), *Getting the measure of fuel poverty: final report of the Fuel Poverty Review*
- Inforse [link](#)
- Infrastructure Development Company Limited IDCOL (2017), *Annual Report 2017*
- International Energy Agency (IEA) (2012), *WEO - Methodology for energy access analysis*

Bibliography (2/3)

- International Energy Agency IEA (2014), *“Technology Road Map Solar Photovoltaic Energy”*
- International Energy Agency IEA PVPS (2014), *“Trends 2014 in Photovoltaics Applications”*
- International Energy Agency IEA-ETSAP and IRENA (*Hydropower Technology Brief E06 – February 2015*)
- International Energy Agency (IEA) (2016), *WEO - Special Report 2016 Energy and Air Pollution*
- International Energy Agency (IEA) (2016), *Water Energy Nexus - Excerpt from the World Energy Outlook 2016*
- International Energy Agency (IEA) (2017), *Energy Access Outlook 2017 – From Poverty to Prosperity*
- International Energy Agency (IEA) (2017), *World Energy Outlook 2017*
- International Energy Agency (IEA) database, *Policies & Measures* [link](#)
- International Renewable Energy Agency (IRENA) (2018), *Renewable Power Generation Costs in 2017, International Renewable Energy Agency, Abu Dhabi*
- Kirk, R., Smith, R., Uma, V.V.N., Kishore, J.Joshi V., and M.A.K. Khalil (2000), *Greenhouse implication of household stoves: An analysis for India*, vol. 25: 741-763
- Li, K., Lloyd, B., Liang, X., Wei, Y. (2014), *Energy poor or fuel poor: What are the differences?*
- Matly, M. (2003), *Energy, Poverty, and Gender – Rural Electrification in Indonesia and Sri Lanka: from Socail Analysis to Reform of the Power Sector*, World Bank report 34538
- OPEC Fund for International Development (OFID) [link](#)
- Oxford Poverty & Human Development Initiative (OPHI); Nussbaumer, P., Bazilian, M., Modi, V., Yumkella, K. (2011), *Measuring Energy Poverty: Focusing on What Matters*, working paper No. 42
- Practical Action Consulting (PAC) and EUEI PDF (2015) - *Building Energy Access Markets report*
- Schlag, N., Zuzarte, F. (2008), *Market Barriers to Clean Cooking Fuels in Sub-Saharan Africa: A Review of Literature*
- Smith et al. (2000), *Greenhouse implication of household stoves: An analysis for India*
- Sustainable energy for all (2012), *“A Global Action Agenda, Pathways for Concerted Action toward Sustainable Energy for All”*

Bibliography (3/3)

- Sustainable Energy for All, *Global Tracking Framework, Progress toward Sustainable Energy (2017)*, the International Bank for Reconstruction and Development / The World Bank and the International Energy Agency
- United Nations Development Programme (UNDP) (2009), *The energy access situation in developing countries*
- United Nations Development Programme (UNDP) (2010), *Human Development Report 2010*
- United Nations Industrial Development Organization (UNIDO) (2016), *World Small Hydropower Development Report 2016*
- Urmee, T. (2014), “A review of improved cookstove technologies and programs”
- Williams, R.H. (2009), *Toward a Global Clean Cooking Fuel Initiative*
- World Bank (2008), *Designing Sustainable Off-Grid Rural Electrification Projects: Principles and Practices*
- World Bank (2008), *Reducing the Cost of Grid Extension for Rural Electrification*, ESM 227
- World Bank Group (2014), *Scaling Up Access to Electricity: the case of Bangladesh report*
- World Bank Group (2016), *RISE (Regulatory Indicators for Sustainable Energy) rankings report*
- World Bank Group (2017), *Electricity access database* [link](#)
- World Bank Group (2017), *State of Electricity Access report*
- World Bank Group - Lighting Global Program (2018), *The 2018 Global Off-Grid Solar Market Trends Report*,
- World Bank online database on population ([link](#)), electricity consumption ([link](#))
- World Economic Forum (2011), *Water security, the water-food-energy-climate nexus*
- World Health Organization (WHO) – International Agency for Research on Cancer (2010), *vol. 95 Household Use of Solid Fuels and High-temperature Frying*
- World Health Organization (WHO) (2009), *Mortality and Burden of Disease Attributable to Selected Major Risks*
- World Health Organization (WHO) (2014), *Burden of disease from Household Air Pollution for 2012*
- World Health Organization (WHO) (2015), *Health in the green economy*
- World Health Organization (WHO) (2016), *Preventing disease through healthy environments*

Picture credits

- **Slide 48:** <http://www.majazetterberg.com/gallery/gravity-light/>
- **Slide 66:** Low Tech Magazine (<http://www.lowtechmagazine.com/2014/06/thermal-efficiency-cooking-stoves.html>)
- **Slide 80:** Rwanda - Scaling-Up Energy Access Project (SEAP), African Development Bank
- **Slide 81, 82:** Business solutions to enable energy access for all report, World Business Council for Sustainable Development
- **Slide 85:** HOW IT WORKS (PAYG), Helios solutions (SL) Limited

Relatively high energy costs compared to purchasing power put some European population in situation of *Fuel Poverty*

Population at risk in the EU

%, Eurostat data, 2012

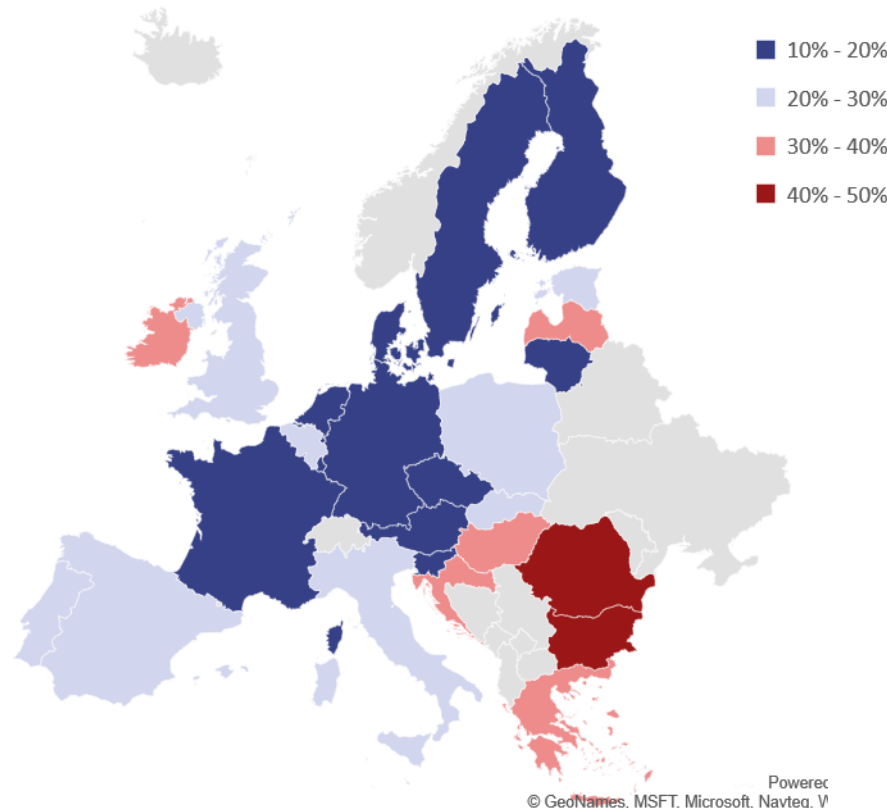

Almost 55 million EU citizens were unable to keep their home adequately warm in 2012

- **Within the European Union, vast majority of houses are connected to the energy network. But there are situations where individuals, or households, are unable to adequately heat or provide necessary energy services in their homes at affordable cost – these relates to “Fuel Poverty”.**
- Eurostat collects data about the population at-risk-for-poverty (AROPE), which is defined as households with an income of 60% of the median national income. However, energy poverty arise from a variety of factors, among which: **low incomes, poor thermal efficiency of buildings, and high energy costs.**
- The highest shares of populations at risk are mainly found in the **Southern and Eastern regions of Europe**, especially in the **newer Member States**, as Romania, Hungary, Croatia, Cyprus, Latvia, Lithuania and those hit by **recent economic turmoil**, as Ireland and Greece.

Electricity and non-solid fuels provides modern energy services for households in developed economies

Global energy consumption mix
(Million tonnes of oil equivalent)

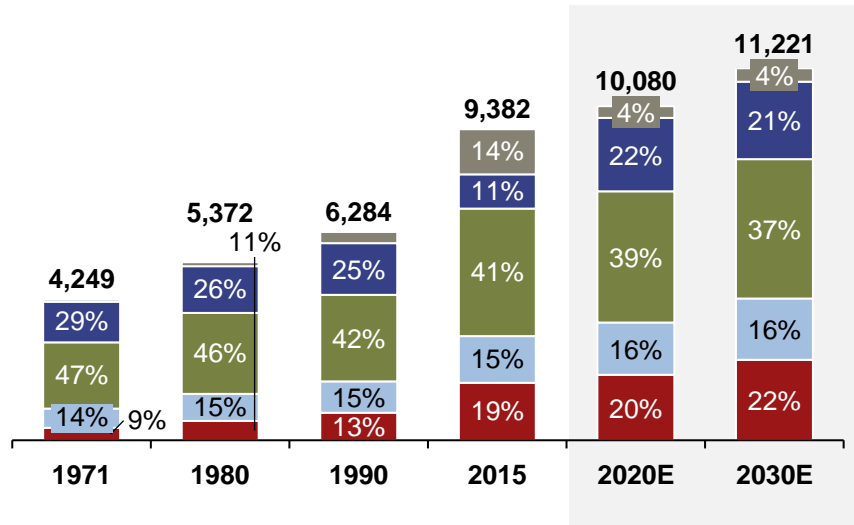

Household final consumption in 2013

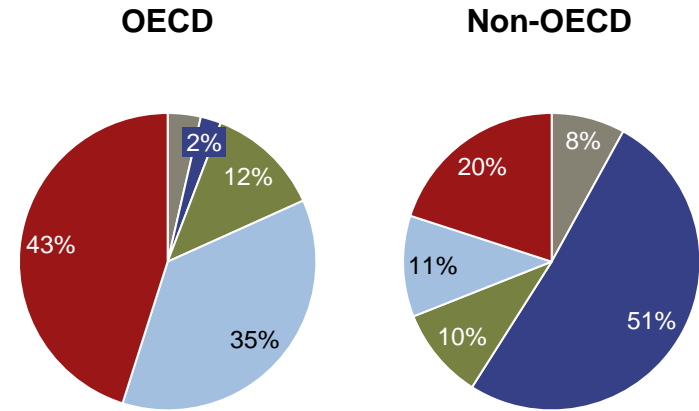

- Other²
- Solid fuels
- Liquid fuels
- Gaseous fuels
- Electricity

1. Include liquid fuels (e.g. kerosene, ethanol) and gaseous fuels (e.g. natural gas, LPG, diesel, biogas). They differ from solid-fuels including biomass (wood, dung, agricultural residues), coal and lignite, typically used in traditional cooking.

2. Includes direct heat and other renewables.

Source: IEA(2015) World Energy Outlook; IEA (2015) "Headline Energy Data";

The A.T. Kearney Energy Transition Institute is a nonprofit organization that provides leading insights on global trends in energy transition, technologies, and strategic implications for private-sector businesses and public-sector institutions. The Institute is dedicated to combining objective technological insights with economic perspectives to define the consequences and opportunities for decision makers in a rapidly changing energy landscape. The Institute's independence fosters unbiased primary insights and the ability to co-create new ideas with sponsors and relevant stakeholders.

For further information about the A.T. Kearney Energy Transition Institute and possible ways of collaboration, please visit www.energy-transition-institute.com, or contact us at contact@energy-transition-institute.com.

Permission is hereby granted to reproduce and distribute copies of this work for personal or nonprofit educational purposes. Any copy or extract has to refer to the copyright of the A.T. Kearney Energy Transition Institute.